



LOYTEC

FACTS⁺

Innovative Building Automation – Product Solutions



Member of:



BACnet
INTEREST GROUP EUROPE

BACnet
INTERNATIONAL

enocean alliance
Member

KNX







EUROPEAN
BUILDING
AUTOMATION
CONTROL
ASSOCIATION

Digital Illumination
Interface Alliance

LOYTEC Product Overview.

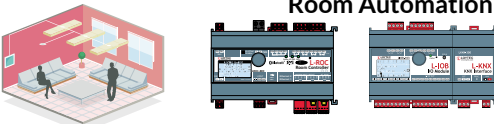
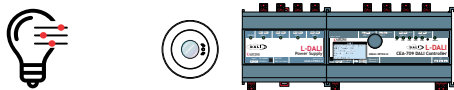
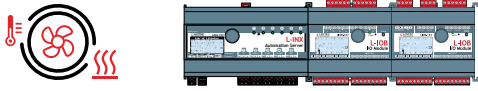
LWEB-900 Building Management System

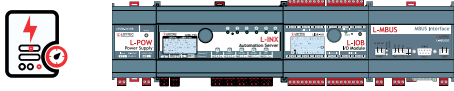
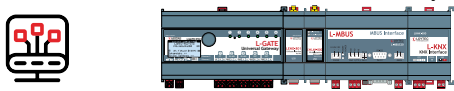
LWEB-900 Server	LWEB-900 Clients	BACnet B-OWS	OPC XML-DA	Alarming	Schedule Configuration	Trending	E-mail	Reporting	Parameter Editor	Web cam Integration
User Management	Global Connections	Device Manager	Device Configuration	L-STUDIO	Visualization	Watch View	Identification Keys	Network Security and VPN	LWEB-802/803	Multi-Site

		LON	BACnet	KNX	EnOcean	Bluetooth	DALI	SMI	Modbus	M-Bus	MP-Bus	OPC	Programmable	IoT
User Interface  L-VIS L-WEB L-STAT L-PAD		✓	✓			✓			✓			✓	✓	✓
Room Automation  L-ROC L-INX L-IOB L-PAD		✓	✓	✓	✓	✓	✓	✓	✓	✓	✓	✓	✓	✓
Lighting Control  L-DALI		✓	✓		✓	✓	✓	✓	✓			✓	✓	✓
HVAC Control  L-INX L-IOB L-MBUS L-MPBUS		✓	✓	✓	✓		✓		✓	✓	✓	✓	✓	✓
I/O Controller  L-IOB		✓	✓		✓		✓		✓		✓	✓	✓	✓
Energy Management, Metering  L-INX L-IOB L-MBUS		✓	✓	✓	✓				✓	✓	✓	✓	✓	✓
Gateways  L-GATE L-INX L-DALI		✓	✓	✓	✓		✓	✓	✓	✓	✓	✓		✓
Network Infrastructure  L-IP L-Switch NIC		✓	✓									✓		

L-WEB Building Management System.

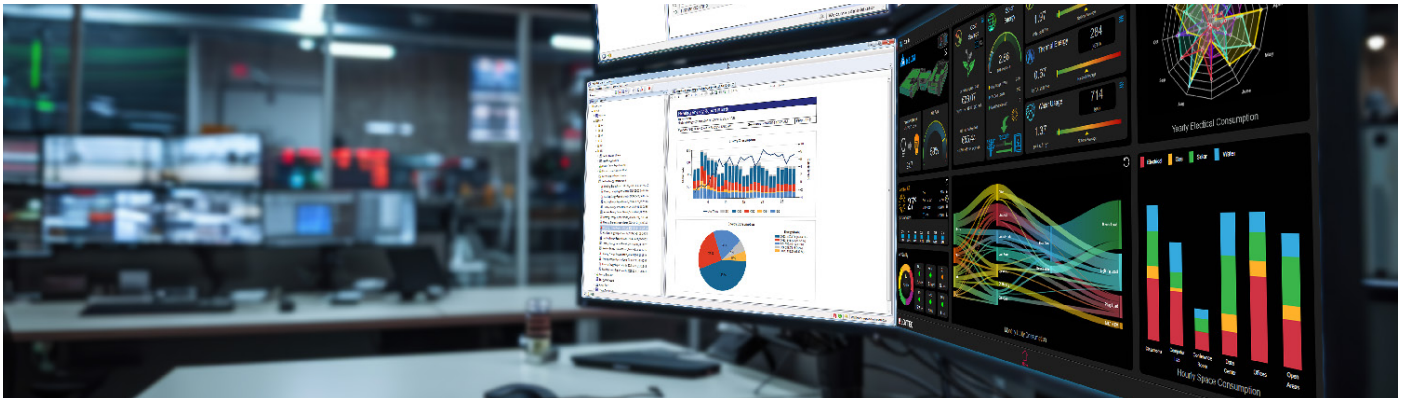

The L-WEB System is a powerful building management system platform for managing distributed building automation systems of any size. Maximum flexibility and scalability is achieved through the LWEB-900 client/server architecture in combination with the distributed LOYTEC L-INX Automation Servers and L-ROC Room Controllers.

The L-WEB System provides:

- Visualization of customized graphic pages with dynamic content from a standard web browser
- Analysis and storage of long term data
- Management of distributed time schedules
- Alarm management
- Organization of system parameters and data points
- Device management and updates for all LOYTEC devices
- Reporting, e.g. to document the energy consumption of a building
- Integration of webcams
- Multi-site functionality
- VPN

Multiple users can simultaneously use the system functions on different PCs. LWEB-900 provides comprehensive user management and asset tracking features. Alarming, scheduling and trending (AST™) functions distributed to LOYTEC devices are automatically synchronized to the LWEB-900 server. AST™ functions are ready where they are needed in building automation and fully integrated into the L-WEB System.

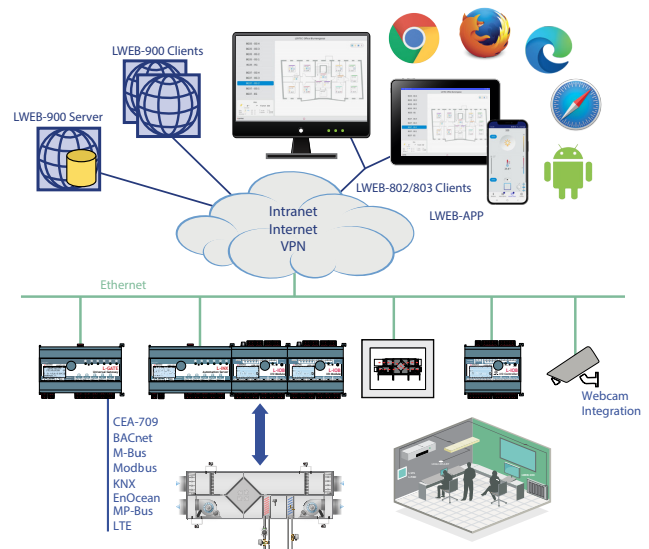
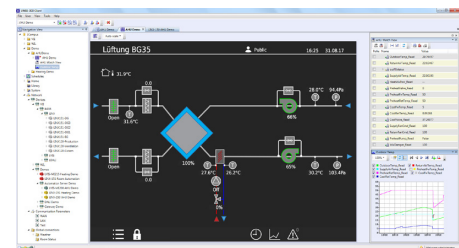

Individualized graphics can be created for specific tasks which are available to different users via LWEB-803 dashboards, LWEB-802 HTML5 user interfaces, or through the LWEB-900 building management system.

Connectivity Products.

The LGATE-902 and LGATE-952 are powerful universal gateways that can host user specific graphical pages to be used with LWEB-802/803. They can simultaneously integrate and map data points from multiple open protocols. Local operation and override is provided by the built-in jog dial and the backlit display (128x64 pixels). Device and data point information is provided by the Web interface and shown on the display via symbols and in text format.

The LIP-ME201C, LIP-ME202C, and LIP-ME204C BACnet/IP Routers connect BACnet MS/TP channels to a BACnet/IP network. The BACnet routers are compliant with the standards ASHRAE 135-2012 and ISO 16484-5:2012. The routers can be configured to act as a BACnet Broadcast Management Device (BBMD). The L-IP BACnet/IP Routers also provide Foreign Device support.

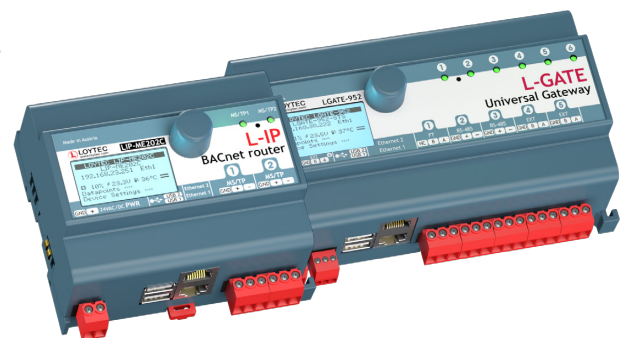

The L-IP Routers LIP-1ECTC, LIP-3ECTC, LIP-33ECTC, and LIP-3333ECTC connect twisted pair channels (TP/FT-10 or TP/XF-1250) with the Ethernet/IP channel (IP-852) in LonMark Systems. L-IP routes CEA-709 packets through an IP based network such as a LAN (Ethernet), an Intranet, or even the Internet.

L-INX Automation Servers.

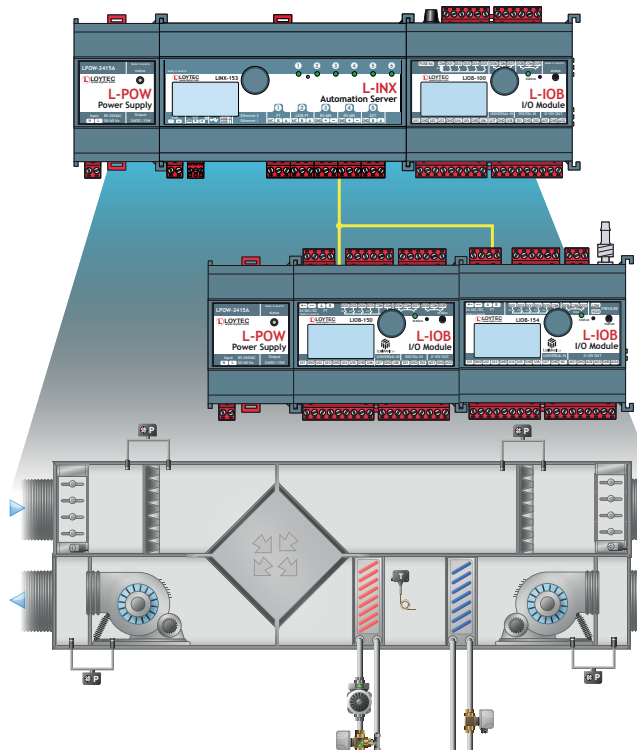

The programmable L-INX Automation Servers are powerful multi-protocol devices that can be expanded by plug and play L-IOB I/O Modules. L-INX Automation Servers feature comprehensive alarming, scheduling, trending (ASTTM), and email notification features. The L-INX can host dynamic graphical pages that can be accessed via a standard web browser.

Protocols supported:

Field level protocols	IP level protocols
BACnet MS/TP	BACnet/IP
LONMARK TP/FT-10	LONMARK IP-852
KNX TP1	KNXnet/IP
M-Bus	OPC XML-DA, OPC UA
Modbus RTU/ASCII	Modbus TCP
EnOcean	HTTPS
SMI	SMTP
MP-Bus	SNMP
	Node.js
	LTE

L-IOB I/O Modules can be connected to the L-INX Automation Servers via LIOB-Connect, LIOB-FT, and LIOB-IP. L-INX integrates smoothly into the L-WEB System via web services. The built-in network security features such as SSL, HTTPS, SSH, and the configurable firewall make the data exchange with the L-INX Automation Servers secure from unauthorized access. L-INX Automation Servers can connect to SMI, MP-Bus, EnOcean, LTE and WLAN through additional interfaces.

L-IOB I/O Controllers & Modules.

The programmable L-IOB I/O Controllers and the L-IOB I/O Modules feature various I/O configurations and are based on 32-bit L-CORE, ensuring first class performance and resources. Some models are equipped with a built-in pressure sensor.

L-IOB I/O Controllers and Modules are available with BACnet/IP or LonMark IP-852 Ethernet connectivity, as well as LonMark TP/FT-10. The L-IOB I/O devices communicate independently via network variables or BACnet objects in the corresponding networks. In addition, L-IOB I/O Modules are available with a LIOB-Connect interface for a fast and easy connection to L-INX Automation Servers or L-ROC Room Controllers.

All L-IOB devices contain a 128 x 64 display with backlight. The display shows device and data point information. A jog dial is used for local operation by navigating through detailed information on the display and for operation and control of data points.

All L-IOB I/O Controllers feature comprehensive alarming and scheduling. IP based L-IOB I/O Controllers feature trending and email notification. They can also host dynamic graphical pages accessible via web browser. Universal I/Os are available on LIOB-110, LIOB-112, LIOB-590, LIOB-592, LIOB-593, LIOB-594, LIOB-595, and LIOB-596.



L-ROC Room Automation.

The L-ROC Room Controller is the core of the revolutionary IP based room automation system that allows for changing room layouts within seconds. L-ROC smoothly integrates in native BACnet/IP Networks and LonMark Systems at the controller level.

The L-STUDIO software allows for the creation and adjustment of flexible room applications incorporating HVAC, lighting, sun blinds and security functions into totally integrated automation systems with very little effort.

An integral part of the L-ROC solution is a web-based room operation from PCs or mobile devices (iOS and Android) via LWEB-803 dashboards (virtual room unit on PC desktop), or LWEB-802 HTML5 pages with the automatic generation of graphic projects for local room operation on L-VIS Touch Panels.

The L-ROC Room Controller family of products integrates DALI-2, KNX, LON, BACnet IP and MS/TP, Modbus, SMI, M-Bus, MP-Bus, Bluetooth and EnOcean subsystems at controller level. These integration capabilities are the foundation for outstanding scalability and flexibility.

The LROC-800 Room Controller extends LOYTEC's L-ROC system with a rich blend of wired, wireless, and electrical interfaces. It is designed for advanced single-room automation applications and scales up to 3 rooms or room segments. Its core feature is a Bluetooth Mesh (SIG) interface for integrating Bluetooth Mesh sensors, luminaires, and other actuators.

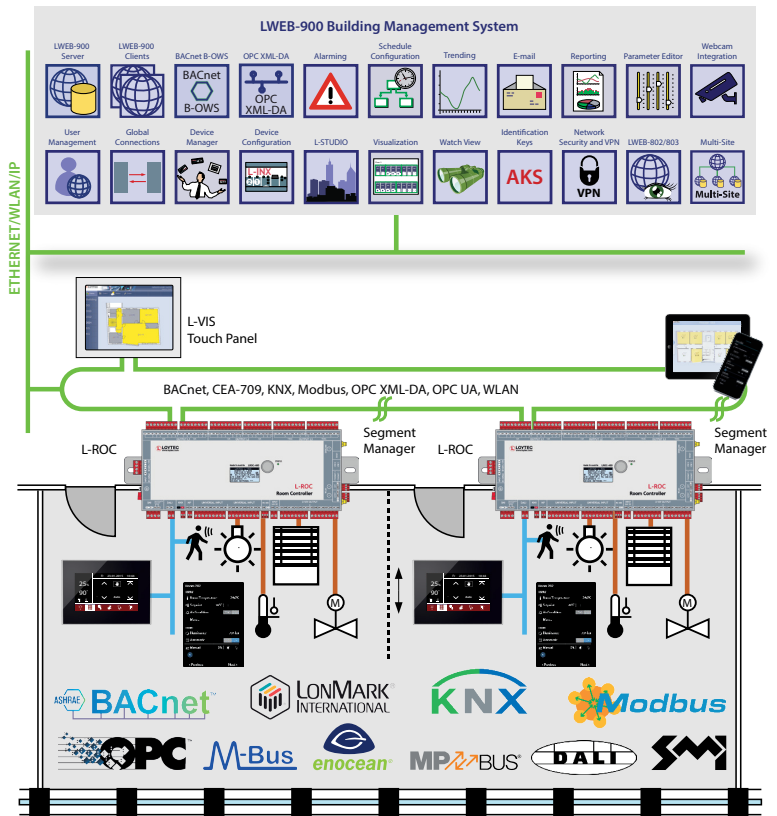

L-DALI Lighting Control.

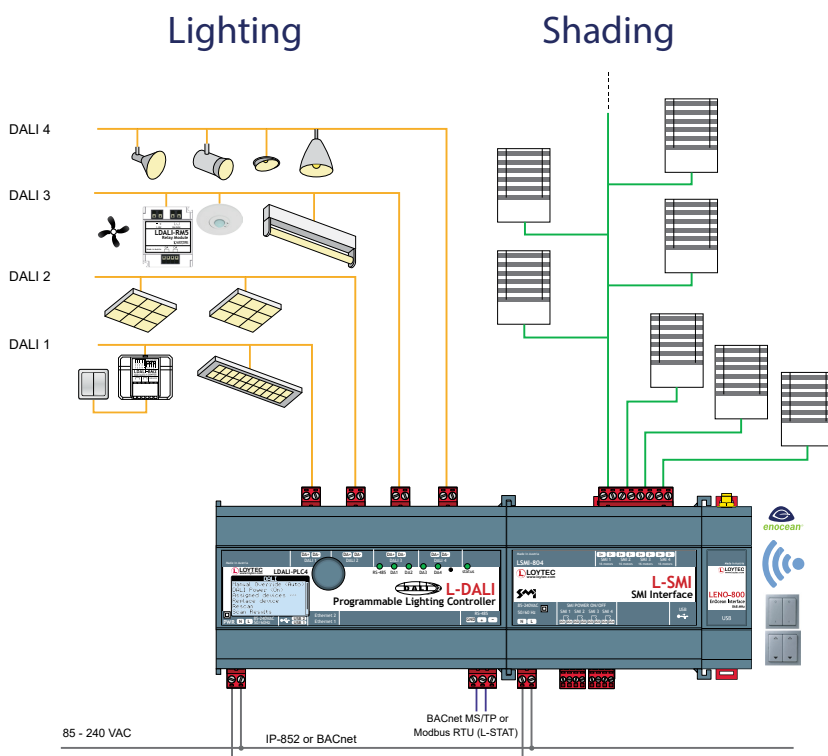

L-DALI Controllers are DALI-2 certified multi-functional devices featuring DALI lighting control and gateway functionality between the DALI protocol (Digital Addressable Lighting Interface) and LonMark Systems or BACnet Networks. In addition to the integration of DALI ballasts and DALI-2 certified input devices the L-DALI controllers support configuration of a variety of L-DALI devices (relay and DALI to 1-10V converter modules, phase-cut dimmers, PWM modules, pushbutton-couplers and multi-sensors).

The built-in web server allows for device configuration, DALI system configuration and maintenance. L-DALI Controllers feature alarming, scheduling, trending (AST™), e-mail notification functionality and together with the new generation of bluetooth-enabled L-DALI multi-sensors, asset tracking functionality and sensor beacon configuration.

EnOcean devices can be integrated via the L-ENO EnOcean interface and, together with the LSMI-804 interface, they can build up an intelligent and efficient sun and anti-glare protection through active slat control and slat adjustment according to the sun position.

LPAD-7 Operator Touch Panels.



IP connectivity is via ethernet ports on the device supporting PoE, bridged or separated network configuration in addition to WLAN wireless. LPAD-7 can communicate with Bluetooth or Bluetooth mesh devices in a space.

LPAD-7 implements the most popular open protocols such as BACnet, Bluetooth, Modbus, OPC XML/DA, OPC UA, EnOcean, LonMark IP852 and FT.

LPAD-7 Operator Touch Panels perfectly act as room operator panels, network thermostats, or generic programmable controllers with integrated capacitive touch screen and a variety of built-in sensors. LPAD-7 perfectly fits the requirements to operate in commercial or residential rooms of any type.

LPAD delivers a modern and slim design installed on a wall.

The LPAD-7 senses temperature, humidity, brightness, and presence. Optional mounting sockets add a variety of additional connectivity capabilities and a number of physical inputs and outputs when required.

The IR receiver detects commands from an IR remote control. The proximity sensor turns on the backlight of the display and the detection distance can be set (20-200 cm).



L-STAT Room Operator Panels.



The L-STAT is a room operator panel with a modern, minimalist look that fits any interior design. It is directly connected to a LOYTEC controller with a Modbus interface.

Up to 16 L-STAT devices can be connected to one controller. L-STAT is equipped with a

segmented LCD display featuring an RGB backlight with adjustable color, offering an elegant way to make the L-STAT match the interior color concept of any building. Eight capacitive touch buttons are used to cycle through sensor values, display parameters, and adjust set points. Additionally, four external buttons can be connected.

Depending on the version, the L-STAT's internal sensors measure temperature, humidity, dew point, ambient light, occupancy, and the CO₂ level of the air. Additionally, the date and time as well as the current level of eco-friendliness in the form of leaves are also displayed on the LCD display.

A buzzer provides acoustic feedback for the touch buttons and can also be used to indicate alarms and error states. To prevent unauthorized modifications, two access levels (end user, system integrator) are provided.

The L-STAT comes with a built-in infrared receiver for comfortable remote control. Custom versions of the L-STAT are available with all three different hardware versions.

Additionally, they can be equipped with an EnOcean interface. In this case, the L-STAT acts as a remote EnOcean transceiver for all controllers supporting an L-STAT interface.



L-VIS Touch Panels.

L-VIS Touch Panels are ideally suited for visualization and operation of various applications in building automation. L-VIS Touch Panels visualize building automation systems, can be used as room units, or make a good choice in conference rooms and reception areas.

L-VIS impresses with its timeless design, harmonic integration into modern and historical architecture, with an extremely user friendly concept. The shallow installation depth and low thermal power loss allow mounting in almost any location.

For the operation and monitoring of information in LonMark Systems, BACnet or Modbus networks, the following types of L-VIS Touch Panels are available:

- 7" L-VIS Touch Panel (LVIS7-32Gx), 1024 x 600, 16.7 million colors, frameless glass front and capacitive touch
- 12.1" L-VIS Touch Panel (LVIS12-32Gx), 1024 x 768, 16.7 million colors, frameless glass front and capacitive touch
- 15" L-VIS Touch Panel (LVIS15-32Gx), 1024 x 768, 16.7 million colors, frameless glass front and capacitive touch



IoT Integration.



The Internet of Things has brought forward an offspring of devices with Web-based interfaces, such as Multimedia projectors, A/V systems, Smart-TVs, or smart light bulbs. LOYTEC's groundbreaking JavaScript-based IoT integration allows to integrate them all.

Typical applications are meeting rooms or auditoriums with scene control of lighting and shading, integration of third-party devices, and operation of multimedia equipment by the touch of a single button. Similar products from the consumer sector like a Sonos® audio system, Philips Hue lights or Alexa and friends can be connected to the LOYTEC building control system.

The IoT function (Node.js, Node-RED) allows connecting the system to almost any cloud service, either for uploading historical data to analytics services, delivering alarm messages to alarm processing services or operating parts of the control system over a cloud service (e.g., scheduling based on Web calendars or booking systems).

Processing Internet information such as weather data in forecast-based control is also possible. Finally, the JavaScript kernel also allows implementing serial protocols to non-standard equipment in primary plant control.

In short: If you can control it via app, you can integrate it into the building automation system or touch panel interface.

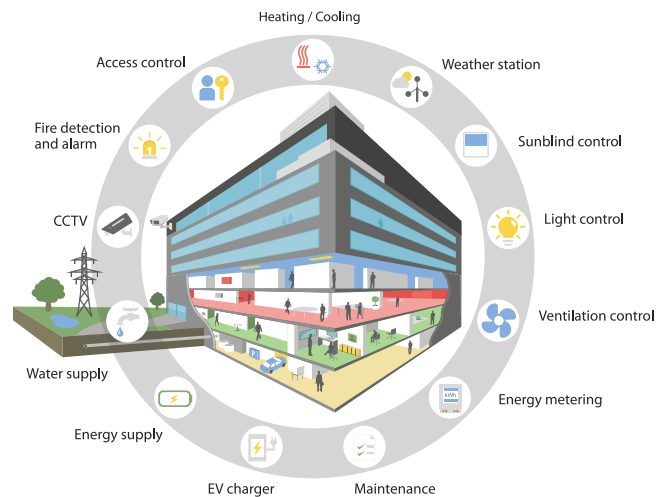

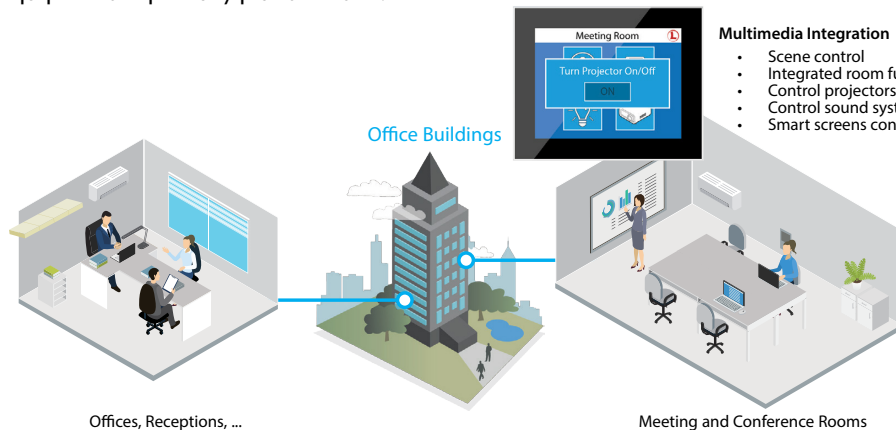

Multimedia Integration

- Scene control
- Integrated room functions
- Control projectors
- Control sound systems
- Smart screens control



Product name	L-WEB Building Management Software			
Model	LWEB-900	LWEB-900-MAX	LWEB-803	LWEB-802
				
Product description	Building Management Software for 10 devices (L-IP Router and L-IOB-I/O Modules connected as extension to the L-INX Automation Servers, L-ROC Room Controllers and L-IOB I/O Controllers do not consume a device license), licenses for 5 LWEB-900 clients and 20 LWEB-80x clients are included, no installation license for end customers	Building management software for an unlimited number of devices, Building Management Software for an unlimited number of devices, licenses for 5 LWEB-900 clients and 20 LWEB-80x clients are included, no installation license for end customers	Graphical user interface, visualization on Windows PC	Graphical user interface via web browser, compatible to Android and iOS
Hardware requirements	LWEB-900 server: PC with at least 2 GHz, 32- or 64-bit processor, 4 GB RAM, 50 GB free hard disk space, Ethernet connection LWEB-900 client: PC with at least 2 GHz, 32- or 64-bit processor, 2 GB RAM, 1 GB free hard disk space, Ethernet connection, screen resolution 1280x720			
Operating system	Windows 10, Windows 11, Windows Server 2012, Windows Server 2016, Windows Server 2019			-
Visualization and operation	■	■	■	■
Graphical view	■	■	■	■
Alarming	■	■	■	■
Scheduling	■	■	■	■
Trending	■	■	■	■
Event log	■	■	-	-
Parameter view	■	■	-	-
Global connections	■	■	-	-
Device manager	■	■	-	-
Device configuration	■	■	-	-
Multiuser system	■	■	■	■
Reporting	■	■	-	-
Watch view	■	■	-	-
AKS-Identification keys	■	■	-	-
Webcam integration	■	■	-	-
Scripting	■	■	-	-
Recommended limit for SQLite	10 GBytes, 1 record =100 bytes -> 100.000.000 records			-
Max. number of devices	1000		-	-
Max. number of multi-sites	50		-	-



Product name	L-WEB Building Management Add-on licenses	
Add-on licenses	Description	
LWEB-900-ADD-10	Add-on license for 10 additional devices	
LWEB-900-ADD-MAX	Add-on license for max. 1000 devices	
LWEB-900-CL-5	Add-on license for additional 5 LWEB-900 clients	
LWEB-900-80x-50	Add-on license for additional 50 LWEB-80x clients	
LWEB-900-80x-100	Add-on license for additional 100 LWEB-80x clients	
LWEB-900-80x-MAX	Add-on license for an unlimited number of LWEB-80x clients	
LWEB-900-MS	Add-on license to enable multi-site support	
LWEB-900-VPN-BASE	Add-on license to enable VPN support in LWEB-900 for one project, includes LWEB-900-VPN-MNT for 1 year	
LWEB-900-VPN-MNT	Add-on license to add/remove VPN clients in LWEB-900 for all projects. Valid for 1 year.	

Product name	L-INX Automation Servers		
Model	LINX-153	LINX-154	LINX-215
			
BACnet device profile	B-BC		
Power supply	24 VDC / 24 VAC ± 10%, typ. 2.5 W		
CPU	Quad-core ARM Cortex-A53 @ 1.1GHz		
RAM	1 GByte	1 GByte	1 GByte
FLASH	8 GByte	8 GByte	8 GByte
TP / FT-10 ports	1	-	1
LIOB-FT ports	1	-	1
RS-485 ports	2	4	1
Extension port (KNX)	1	1	1
Extension / Serial port (M-Bus)			
Total number of data points	30000		10000
OPC data points	10000		5000
BACnet objects	2000		1000
BACnet calendar	25		25
BACnet scheduler	100		100
BACnet notification classes	32		32
Trend logs	512 (13 000 000 entries, ≈ 200 MB)		512 (13 000 000 entries, ≈ 200 MB)
LonMark calendar	1 (25 calendar patterns)		1 (25 calendar patterns)
LonMark scheduler	100		100
LonMark alarm servers	1		1
Modbus data points	2000	5000	2000
L-WEB clients	32		32
L-IOB I/O modules	Up to 24 L-IOB I/O Modules in any combination of type LIOB-Connect, LIOB-FT, LIOB-IP852/BIP		Up to 8 L-IOB I/O Modules in any combination of type LIOB-Connect, LIOB-FT, LIOB-IP852
IEC-61131-3	■	■	■
IEC-61499	■	■	■
CEA-709 Router	■	-	■
CEA-709 RNI	■	-	■
CEA-709 (FT)	■	■	■
CEA-852 (IP)	■	■	■
BACnet Router	■	■	■
BACnet MS / TP	■	■	■
BACnet TCP / IP	■	■	■
BBMD	■	■	■
Modbus RTU/ASCII	■ ¹	■ ¹	■ ¹
Modbus TCP / IP	■	■	■
M-Bus	■ ²	-	■ ²
MP-Bus	■ ³	-	■ ³
SMI	■ ³	-	■ ³
KNX TP1	■ ²	-	■ ²
KNX IP	■	-	■
EnOcean	■ ³	-	■ ³
OPC XML-DA	■	■	■
OPC UA	■	■	■
SNMP	■	■	■
LIOB-Connect	■	■	■
LIOB FT + IP	■	■	■
128 x 64 graphic display with backlight	■	■	■
USB	■	■	■
Ethernet switch	■	■	■
WLAN	■ ³	■ ³	■ ³
LTE	■ ³	■ ³	■ ³
IoT	■	■	■
L-STUDIO	■	■	■
SSH, HTTPS, Firewall	■	■	■
Operating conditions	0 °C to 50 °C, 10–90 % RH, noncondensing, degree of protection: IP40, IP20 (terminals)		
Dimensions (L x W x H, mm)	159 x 100 x 75		107 x 100 x 75
Certificates	CE, FCC, BTL, UL	CE, FCC, BTL, UL	CE, FCC, BTL, UL

1. Modbus RTU/ASCII can only be used if BACnet MS / TP is not active on the same port.

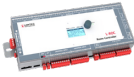

2. M-Bus and KNX TP1 can be used alternatively only on this model. An expansion module is needed and must be ordered separately.

3. To operate these protocols, an expansion module is needed and must be ordered separately.

Product name	L-ROC Room Controller			
	LROC-102	LROC-400	LROC-401	LROC-402
Model				
Power supply	24 VDC / 24 VAC ±10%, typ. 2.5 W	24 VDC or 85 – 240 VAC, 50 – 60 Hz (both supplies can be redundantly fed, do not connect 24VDC if SMI or DALI are used)		
CPU	Quad-core ARM Cortex-A53 @ 1.1GHz			
RAM	1 GByte	1 GByte	1 GByte	1 GByte
FLASH	8 GByte	8 GByte	8 GByte	8 GByte
TP / FT-10 ports	1	-	-	-
LIOB-FT ports	1	-	-	-
RS-485 ports ³	1	1	1	-
Extension port (KNX)	1	1	1	1
Extension/Serial port (M-Bus)	1	1	1	-
Total number of data points	30000	30000	30000	30000
OPC data points	10000	10000	10000	10000
BACnet objects	4000	4000	4000	4000
BACnet calendar	25	25	25	25
BACnet scheduler	100	100	100	100
BACnet notification classes	32	32	32	32
Trend logs	512 (13 000 000 entries, ≈ 200 MB)			
LonMark calendar	1 (25 calendar patterns)	1 (25 calendar patterns)	1 (25 calendar patterns)	1 (25 calendar patterns)
LonMark scheduler	100	100	100	100
LonMark alarm servers	1	1	1	1
Modbus data points	4000	2000	2000	2000
L-WEB clients	32	32	32	32
L-IOB I/O modules	Up to 24 (L-IOB I/O Modules in any combination of type LIOB-Connect, LIOB-FT, and LIOB-IP852 / LIOB-BIP)	2 x LIOB-45x/LIOB-55x/56x		
IEC-61131-3	-	-	-	-
IEC-61499	■	■	■	■
CEA-709 Router	■	■	■	-
CEA-709 RNI	-	-	-	-
CEA-709 (FT)	■	-	-	-
CEA-852 (IP)	■	■	■	■
BACnet Router	■	■	■	■
BACnet MS / TP	■	■	■	-
BACnet TCP / IP / SC	■	■	■	■
BBMD	■	■	■	■
Modbus RTU/ASCII	■ ³	■ ³	■ ³	-
Modbus TCP / IP	■	■	■	■
M-Bus	■ ⁴	■ ⁵	■ ⁵	-
KNX TP1	■ ⁴	■	■	■
KNX IP	■	■	■	■
SMI	■ ⁵	■	■	■ ⁵
EnOcean	■ ⁵	■	■	■ ⁵
OPC XML-DA	■	■	■	■
OPC UA	■	■	■	■
SNMP	■	■	■	■
LIOB Connect	■	-	-	-
LIOB FT + IP	■	■ (IP only)	■ (IP only)	■ (IP only)
128 x 64 graphic display with backlight	■	■	■	■
microSD Card	-	-	-	-
USB	■	■	■	■
Ethernet switch	■	■	■	■
WLAN	■ ⁵	■ ⁵	■ ⁵	■ ⁵
LTE	■ ⁵	■ ⁵	■ ⁵	■ ⁵
IoT	■	■	■	■
L-STUDIO	■ (IEC 61499 only)	■ (IEC 61499 only)	■ (IEC 61499 only)	■ (IEC 61499 only)
SSH, HTTPS, Firewall	■	■	■	■
Operating conditions	0 °C to 50°C, 10–90 % RH, noncondensing, degree of protection: IP40, IP20 (terminals)	0 °C to 40 °C, 10–90 % RH, noncondensing, degree of protection: IP40, IP20 (terminals)		
Dimensions (L x W x H, mm)	159 x 100 x 75	290 x 144 x 54	290 x 144 x 54	290 x 144 x 54
Certificates	CE, FCC, BTL, UL	CE, FCC, BTL, UL	CE, FCC, BTL, UL	CE, FCC, BTL, UL

1. This model can be configured to have either FT or IP active for CEA-709.
2. This model can be configured to have either MS / TP or IP active for BACnet.
3. Modbus RTU/ASCII can only be used if BACnet MS / TP is not active on this model.

4. M-Bus and KNX TP1 can be used alternatively only on this model. An expansion module is needed and must be ordered separately.
5. To operate these protocols, an expansion module is needed and must be ordered separately.

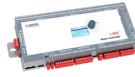
Product name	L-ROC Room Controller		
	LROC-400	LROC-401	LROC-402
Model			
MP-Bus (actuator)	■	■	■
Universal Input (UI)	10	-	10
Digital Input (DI)	2	-	2
Analog Output (AO)	8	-	8
Digital Output (DO)	32 (24 x Relay, 8 x TRIAC) Relay : 10 A TRIAC : 0.5 A @ 24-240 VAC	-	32 (24 x Relay, 8 x TRIAC) Relay : 10 A TRIAC : 0.5 A @ 24-240 VAC
Max. number of Rooms /Segments	8	16	8
SMI devices (via built-in interface)	1 x 16	1 x 16	-
SMI devices via LSMI-800	1 x 16	1 x 16	1 x 16
SMI devices via LSMI-804	4 x 16	4 x 16	4 x 16
SMI devices maximum	96	96	64
EnOcean devices (via built-in interface)	32	64	-
EnOcean devices via LENO-80x	-	-	32
EnOcean devices (maximum)	64	64	64
EnOcean devices commissioning limit	32	64	32
L-STAT Room operator panels	8	16	8
DALI power supply	1 (16 VDC,160 mA guaranteed supply current, 250 mA max. supply current)	1 (16 VDC,160 mA guaranteed supply current, 250 mA max. supply current)	-
DALI devices	64	64	-
DALI groups	16	16	-
DALI sensors	16	16	-
DALI pushbuttons (LDALI-BM2)	64 pushbutton coupler	64 pushbutton coupler	-
MP-Bus devices (via built-in interface)	1 x 8 (16 MPL)	1 x 8 (16 MPL)	1 x 8 (16 MPL)
MP-Bus devices via LMPBUS-804	4 x 8 (16 MPL)	4 x 8 (16 MPL)	4 x 8 (16 MPL)
MP-Bus devices (maximum)	80	80	80

Product name	L-ROC Room Controller
Model	LROC-800
	
Power supply	85 V - 277 V AC
CPU	Quad-core ARM Cortex-A53 @ 1.1GHz
RAM	1 GByte
FLASH	8 GByte
Universal I/O	12 (U, R) ¹
Digital Output (DO)	3 TRIACS (0.5 A), 4 Relays (10 A)
Total number of data points	15000
OPC data points	5000
L-WEB clients	32
Max. number of Rooms /Segments	3
Trend logs (BACnet or generic)	512 (13 000 000 entries, ≈ 200 MB)
Total trended data points	2000
BACnet client mappings	2500
BACnet objects	1000 (analog, binary, multi-state)
BACnet calendar	25
BACnet scheduler	100
BACnet notification classes	32
Bluetooth datapoints	3000
Bluetooth devices	100
CEA-709 network variables (NVs)	1000
CEA-709 Alias NVs	2000
CEA-709 External NVs (polling)	2000
CEA-709 address table entries	1000 (non-ECS mode: 15)
L-STUDIO	■
LonMark calendar	1 (25 calendar patterns)
LonMark scheduler	100
LonMark alarm servers	1
BACnet Router	■
BACnet MS / TP	■
BACnet TCP / IP / SC	■
BBMD	■
OPC XML-DA	■
OPC UA	■
SNMP	■
LIOB Connect	-
LIOB FT + IP	■ (IP only)
128 x 64 graphic display with backlight	■
LSTAT ports	1
USB	■
Ethernet switch	■
WLAN	■
SMI	1 integrated, or ■ ²
EnOcean	■ ²
LTE	■ ²
MP-Bus	■ ²
RS-232	■ ²
IoT	■
SSH, HTTPS, Firewall	■
Operating conditions	0 °C to 40 °C, 10–90 % RH, noncondensing, degree of protection: IP40, IP20 (terminals)
Dimensions (L x W x H, mm)	159 x 100 x 75
Certificates	CE, FCC







1. This model can be configured to have either FT or IP active for CEA-709.











2. To operate these protocols, an expansion module is needed and must be ordered separately.

Product name	L-ROC Room Controller
Model	LROC-800









DALI power supply	1 (16 VDC, 116 mA guaranteed supply current, 125 mA max. supply current)
DALI groups	16
DALI sensors	16
DALI pushbuttons (LDALI-BM2)	64 pushbutton coupler
EnOcean datapoints	1000
EnOcean devices via LENO-80x	32
EnOcean devices commissioning limit	32
MP-Bus devices (per channel)	8 (16 MPL)
MP-Bus devices via LMPBUS-804	4 x 8 (16 MPL)
MP-Bus devices (maximum)	64
SMI devices	16
SMI devices (per channel)	16

Product name	L-IOB I/O Modules (LIOB-Connect)					
Model	LIOB-100	LIOB-101	LIOB-102	LIOB-103	LIOB-110	LIOB-112
						
Power supply	24 V DC / 24 V AC $\pm 10\%$ via L-INX, L-ROC, LIOB-586/587/588/589, L-POW or LIOB-A2/A4 via LIOB-Connect					
Universal Input (UI)	8	8	6	6	-	-
Digital Input (DI)	2	16	-	-	-	-
Analog Output (AO)	2	-	6	6	-	-
Digital Output (DO)	9 (5 x Relay 6A @ 250 VAC, 4 x TRIAC 0.5A @ 24–230 VAC)	-	8 (Relay 6A @ 250 VAC)	5 (Relay 16A @ 250 VAC)	-	-
Universal I/O (IO)	-	-	-	-	20	40 ¹
Connection	LIOB-Connect	LIOB-Connect	LIOB-Connect	LIOB-Connect	LIOB-Connect	LIOB-Connect
128x64 graphic display with backlight	■	■	■	■	■	■
Ethernet switch	-	-	-	-	-	-
Operating conditions	0 °C to 50 °C, 10–90 % RH, noncondensing, degree of protection: IP40, IP20 (terminals)					
Dimensions (L x W x H, mm)	107 x 100 x 75					159 x 100 x 75
Certificates	CE, FCC, UL	CE, FCC, UL	CE, FCC, UL	CE, FCC, UL	CE, FCC	CE, FCC

Product name	I/O Modules (LIOB LonMark TP / FT-10)					I/O Modules (LIOB LonMark IP-852)				
Model	LIOB-150	LIOB-151	LIOB-152	LIOB-153	LIOB-154	LIOB-450	LIOB-451	LIOB-452	LIOB-453	LIOB-454
										
Power supply	24 V DC / VAC $\pm 10\%$ via L-POW, or with an external power supply									
Universal Input (UI)	8	8	6	6	7	8	8	6	6	7
Digital Input (DI)	2	12	-	-	-	2	12	-	-	-
Analog Output (AO)	2	-	6	6	4	2	-	6	6	4
Digital Output (DO)	8 (4 x Relay 6A @ 250 VAC, 4 x TRIAC 0.5A @ 24–230 VAC)	-	8 (Relay 6A @ 250 VAC)	5 (4 x Relay 16A ¹ @ 250 VAC, 1 x Relay 6A @ 250 VAC)	7 (5 x Relay 6A @ 250 VAC, 2 x TRIAC 0.5A @ 24–230 VAC)	8 (4 x Relay 6A @ 250 VAC, 4 x TRIAC 0.5A @ 24–230 VAC)	-	8 (Relay 6A @ 250 VAC)	5 (4 x Relay 16A ² @ 250 VAC, 1 x Relay 6A @ 250 VAC)	7 (5 x Relay 6A @ 250 VAC, 2 x TRIAC 0.5A @ 24–230 VAC)
Differential pressure sensor	-	-	-	-	± 500 Pa	-	-	-	-	± 500 Pa
Connection	Twisted pair	Twisted pair	Twisted pair	Twisted pair	Twisted pair	Ethernet	Ethernet	Ethernet	Ethernet	Ethernet
128x64 graphic display with backlight	■	■	■	■	■	■	■	■	■	■
Ethernet switch	-	-	-	-	-	■	■	■	■	■
Operating conditions	0 °C to 50 °C, 10–90% RH, noncondensing, degree of protection: IP40, IP20 (terminals)									
Dimensions (L x W x H, mm)	107 x 100 x 75									
Certificates	CE, FCC, LonMark, UL									

1. O29-O40 are internally connected to IO29-IO40 and provide 4-20 mA outputs in parallel to the 0-10 V outputs on IO29-IO40

2. UL: 8A

Product name	L-IOB I/O Modules (BACnet IP)						
Model	LIOB-550	LIOB-551	LIOB-552	LIOB-553	LIOB-554	LIOB-560	LIOB-562
							
BACnet device profile	B-BC						
Power supply	24 VDC / VAC $\pm 10\%$ via L-POW, or with an external power supply					24 VDC / 24 VAC $\pm 10\%$	
Power consumption	4.5 W (relays on)	4.5 W	4.5 W (relays on)	4.5 W (relays on)	4.5 W (relays on)	4.5 W ²	2.5 W + 0.5 W for each Oxx (max 6 W) ²
Universal I/O (IO)	-	-	-	-	-	20	40 ¹
Universal Input (UI)	8	8	6	6	7	-	-
Digital Input (DI)	2	12	-	-	-	-	-
Analog Output (AO)	2	-	6	6	4	-	-
Digital Output (DO)	8 (4 x Relay 6A @ 250 VAC, 4 x TRIAC 0.5A @ 24–230 VAC)	-	8 (Relay 6A @ 250 VAC)	5 (4 x Relay 16A ³ @ 250 VAC, 1 x Relay 6A @ 250 VAC)	7 (5 x Relay 6A @ 250 VAC, 2 x TRIAC 0.5A @ 24–230 VAC)	-	-
Differential pressure sensor	-	-	-	-	± 500 Pa	-	-
OPC data points	100						200
BACnet objects	1 (Per I/O)						
BACnet calendar	10						
BACnet scheduler	5						
Trend logs	10 (130000 entries, ≈ 2 MB)					20 (260000 entries, ≈ 4 MB)	40 (520000 entries, ≈ 8 MB)
Alarm logs	5						
Connection	Ethernet	Ethernet	Ethernet	Ethernet	Ethernet	Ethernet	Ethernet
128x64 graphic display with backlight	■	■	■	■	■	■	■
Ethernet switch	■	■	■	■	■	■	■
Operating conditions	0 °C to 50 °C, 10–90 % RH, noncondensing, degree of protection: IP40, IP20 (terminals)						
Dimensions (L x W x H, mm)	107 x 100 x 75						159 x 100 x 75
Certificates	CE, FCC, BTL, UL	CE, FCC, BTL, UL	CE, FCC, BTL, UL	CE, FCC, BTL, UL	CE, FCC, BTL, UL	CE, FCC, BTL	CE, FCC, BTL

Product name	LOYBT I/O Module
Model	LOYBT-IO1





Power supply	24 VDC/ VAC SELV $\pm 10\%$ via LPOW-2415B, or with an external power supply 230 V AC: 85–240 V AC, 50/60 Hz
Interfaces	Bluetooth SIG Mesh
Power consumption	max. 1.7 W
Universal I/O (IO)	4 x Universal I/O (U), 4 x Universal I/O (U,I), 4 x Universal I/O (U,R) ⁴
Digital Output (DO)	6 (4 x Relay 2A, 30V DC / 600mA, 125 V AC; 2 x TRIAC 0.3A, 24–240 V AC)
Interfaces	Bluetooth SIG Mesh
Bluetooth protocol conformance	Declaration ID: Design Number (DN) Q301729 contains qualified designs: 239299 (controller subsystem Bluetooth 5.4), 239354 (host subsystem Bluetooth 5.4), and 226841 (Mesh Protocol 1.1, Mesh Model 1.1)
Operating conditions	0 °C to 50 °C, 10–90 % RH, noncondensing, degree of protection: IP40, IP20 (terminals)
Dimensions (L x W x H, mm)	107 x 100 x 75
Certificates	CE, FCC

1. O29-O40 are internally connected to IO29-IO40 and provide 4–20 mA outputs in parallel to the 0–10 V outputs on IO29-IO40

2. Add external load: Sum of max. current drawn from all outputs x 24V

3. UL: 8A

4. U: 0–10V input or 0–10V output, I: 4–20 mA input (only available on UIO 5–8), R: resistance measurement (only available on UIO 1–4)







Product name	L-IOB Adapter		
Model	LIOB-A2	LIOB-A4	LIOB-A5
			
Connection	4-wire cables	RJ-45	Terminate the LIOB-Connect bus
Operating conditions	0 °C to 50 °C, 10–90 % RH, noncondensing, degree of protection: IP40, IP20 (terminals)		
Dimensions (L x W x H, mm)	55 x 100 x 60	27 x 100 x 60	
Certificates	CE, FCC	CE, FCC	CE, FCC

Product name	LOYCNV Voltage / Current Converter	
Model	LOYCNV-VA8	
		
Power supply	24 V DC \pm 10 %	
Interfaces	8 x Analog Input (0-10 V) 8 x Analog Output (4-20 mA), burden resistance 250-500 Ohm	
Operating conditions	0 °C to 50 °C, 10–90 % RH, noncondensing, degree of protection: IP40, IP20 (terminals)	
Dimensions	55 x 100 x 60 (L x W x H, mm)	
Certificates	CE, FCC	

Product name	LOYCNV Voltage Converter	
Model	LOYCNV-PT1008	
		
Power supply	24 V DC \pm 10 %	
Power consumption	approx. 0.7 W	
Operating conditions	0 °C to 50 °C, 10–90 % RH, noncondensing, degree of protection: IP40, IP20 (terminals)	
Input	8x PT1000 (2-wire connection)	
Output	8x 0 – 10 V	
Dimensions	55 x 100 x 60 (L x W x H, mm)	
Certificates	CE, FCC	







Product name	Relay Interface	
Model	LOYREL-816	
		
Power supply	24 V DC	
Interfaces	8 x Digital Output (16 A Relays) 8 x Digital Input (0/10 V), input 0 V: Relay off, Input 10 V: Relay on	
Power consumption	up to 3.2 W	
Operating conditions	0 °C to 50 °C, 10–90 % RH, noncondensing, degree of protection: IP40, IP20 (terminals)	
Dimensions (L x W x H, mm)	107 x 100 x 60	
Certificates	CE, FCC	

Product name	Triac Interface	
Model	L-TRIAC16	
		
Interfaces	16 x Digital Output (0.5 A TRIAC), 24 V AC - 230 V AC 16 x Digital Input (0/10 V), Input 0 V: TRIAC off, Input 10 V: TRIAC on	
Operating conditions	0 °C to 50 °C, 10–90 % RH, noncondensing, degree of protection: IP40, IP20 (terminals)	
Dimensions (L x W x H, mm)	107 x 100 x 60	
Certificates	CE, FCC	

Product name	L-IOB I/O Controller					
Model	LIOB-585	LIOB-586	LIOB-587	LIOB-588	LIOB-589	LIOB-590
						
BACnet device profile	B-BC					
Power supply	24 VDC / 24 VAC ±10 % via L-POW, or with an external power supply					
CPU	A5 (500 MHz)	A5 (500 MHz)	A5 (500 MHz)	A5 (500 MHz)	A5 (500 MHz)	A5 (500 MHz)
RAM	128 MByte	128 MByte	128 MByte	128 MByte	128 MByte	128 MByte
FLASH	4 GByte	4 GByte	4 GByte	4 GByte	4 GByte	4 GByte
Universal Input (UI)	6	6	6	10	10	-
Digital Input (DI)	-	4	4	-	6	-
Analog Output (AO)	2	-	-	6	6	-
Digital Output (DO)	5 (5 x TRIAC 0.5 A)	6 (6 x Relay 10 A)	6 (6 x Relay 10 A)	8 (8 x Relay 8 A)	4 (4 x Relay 8 A)	-
Universal I/O (IO)	-	-	-	-	-	20
Differential pressure sensor	±500 Pa	-	-	-	-	-
Total number of data points	10000	10000	10000	10000	10000	10000
OPC data points	5000	5000	5000	5000	5000	5000
BACnet objects	1000	1000	1000	1000	1000	1000
BACnet calendar	25	25	25	25	25	25
BACnet scheduler	10	10	10	10	10	10
BACnet notification classes	32	32	32	32	32	32
Trend logs	256 (13 000 000 entries, ≈ 200 MB)					
LonMark calendar	1 (25 calendar patterns)	1 (25 calendar patterns)	1 (25 calendar patterns)	1 (25 calendar patterns)	1 (25 calendar patterns)	1 (25 calendar patterns)
LonMark scheduler	10	10	10	10	10	10
LonMark alarm servers	1	1	1	1	1	1
Modbus data points	300	300	300	300	300	300
L-WEB clients	32	32	32	32	32	32
L-IOB I/O modules	-	1 x LIOB-11x or LIOB-45x/55x/56x	1 x LIOB-11x or LIOB-45x/55x/56x	1 x LIOB-11x or LIOB-45x/55x/56x	1 x LIOB-11x or LIOB-45x/55x/56x	-
Power Measurement	-	-	■	-	-	-
Ethernet switch	■	■	■	■	■	■
128x64 graphic display with backlight	■	■	■	■	■	■
WLAN	■ 1	■ 1	■ 1	■ 1	■ 1	-
EnOcean	■ 1	■ 1	■ 1	■ 1	■ 1	-
MP-Bus	■	■ 1	■ 1	■ 1	■ 1	-
SMI	-	-	-	-	-	-
LTE	■ 1	■ 1	■ 1	■ 1	■ 1	-
IoT	■ 2	■ 2	■ 2	■ 2	■ 2	■ 2
L-STUDIO	■	■	■	■	■	■
Operating conditions	0°C to 50°C, 10–90% RH, noncondensing, degree of protection: IP40, IP20 (terminals)					
Dimensions (L x W x H, mm)	107 x 100 x 75	159 x 100 x 75	159 x 100 x 75	159 x 100 x 75	159 x 100 x 75	107 x 100 x 75
Certificates	CE, FCC, BTL, UL	CE, FCC, BTL, UL	CE, FCC, BTL	CE, FCC, BTL, UL	CE, FCC, BTL, UL	CE, FCC, BTL

1. To operate these protocols, an expansion module is needed and must be ordered separately.

2. To operate IoT functionalities, the L-IOT1 software license is needed and must be ordered separately.







Product name	L-IOB Room Controller		L-IOB I/O Controller			
Model	LIOB-591	LIOB-592	LIOB-593	LIOB-594	LIOB-595	LIOB-596
						
BACnet device profile	B-BC					
Power supply	85 – 240 V AC, 50 – 60 Hz	24 VDC / 24 V AC ±10 % via L-POW, or with an external power supply				
CPU	A5 (500 MHz)	A5 (500 MHz)	A5 (500 MHz)	A5 (500 MHz)	A5 (500 MHz)	A5 (500 MHz)
RAM	128 MByte	128 MByte	128 MByte	128 MByte	128 MByte	128 MByte
FLASH	4 GByte	4 GByte	4 GByte	4 GByte	4 GByte	4 GByte
Universal Input (UI)	-	-	-	-	-	-
Digital Input (DI)	-	-	-	-	-	-
Analog Output (AO)	-	-	-	-	-	-
Digital Output (DO)	1 x TRIAC 1250 W, 230 V AC 3 x TRIAC 300 W, 230 V AC	-	7 (5x Relay 2A, 2x Relay 6A)	7 (5x Relay 2A, 2x Relay 6A)	4 (4x Relay 2A)	6 (4x Relay 2A, 2x TRIAC 0.5A)
Universal I/O (IO)	8 x Universal I/O (U, I, R), ³ 12 x Universal I/O (U) ³	40 ⁴	8 x Universal I/O (U, I, R), ³ 8 x Universal I/O (U) ³	8 x Universal I/O (U, I, R), ³	6 x Universal I/O (U, I, R), ³	8 x Universal I/O (U, I, R), ³
Differential pressure sensor	-	-	-	-	±500 Pa	-
Total number of data points	10000	10000	10000	10000	10000	10000
OPC data points	5000	5000	5000	5000	5000	5000
BACnet objects	500	500	1000	500	500	500
BACnet calendar	25	25	25	25	25	25
BACnet scheduler	10	10	10	10	10	10
BACnet notification classes	32	32	32	32	32	32
Trend logs	256 (13 000 000 entries, ≈ 200 MB)					
LonMark calendar	-	1 (25 calendar patterns)	1 (25 calendar patterns)	1 (25 calendar patterns)	1 (25 calendar patterns)	1 (25 calendar patterns)
LonMark scheduler	-	10	10	10	10	10
LonMark alarm servers	-	1	1	1	1	1
Modbus data points	300	300	500	300	300	300
L-WEB clients	32	32	32	32	32	32
L-IOB I/O modules	1 x LIOB-45x/55x/56x	-	-	-	-	-
Integrated DALI bus power supply	16 VDC, 116 mA max. supply current	-	-	-	-	-
DALI channels	1	-	-	-	-	-
DALI devices	64	-	-	-	-	-
Ethernet switch	■	■	■	■	■	■
128x64 graphic display with backlight	■	■	■	■	■	■
WLAN	■ ¹	■ ¹	■ ¹	■ ¹	■ ¹	■ ¹
EnOcean	■ ¹	■ ¹	■ ¹	■ ¹	■ ¹	■ ¹
MP-Bus	■ ¹	■	■ ¹	■ ¹	■ ¹	■ ¹
SMI	■ ¹	-	-	-	-	-
LTE	■ ¹	■ ¹	■ ¹	■ ¹	■ ¹	■ ¹
IoT	■ ²	■ ²	■ ²	■ ²	■ ²	■ ²
L-STUDIO	■	■	■	■	■	■
Operating conditions	0 °C to 45 °C, 10–90% RH, noncondensing, degree of protection: IP30, IP20 (terminals)	0 °C to 50 °C, 10–90% RH, noncondensing, degree of protection: IP40, IP20 (terminals)				
Dimensions (L x W x H, mm)	199 x 87 x 62	159 x 100 x 75	107 x 100 x 75	107 x 100 x 75	107 x 100 x 75	107 x 100 x 75
Certificates	CE, FCC, BTL	CE, FCC, BTL	CE, FCC, BTL	CE, FCC, BTL	CE, FCC, BTL	CE, FCC, BTL

1. To operate these protocols, an expansion module is needed and must be ordered separately.

2. To operate IoT functionalities, the L-IOT1 software license is needed and must be ordered separately.

3. U: 0-10V input or 0-10V output, I: 4-20 mA input, R: resistance measurement

4. O29-O40 are internally connected to IO29-IO40 and provide 4-20 mA outputs in parallel to the 0-10 V outputs on IO29-IO40

Product name	Gateways					
Model	LGATE-952	LGATE-902	LINX-102	LINX-103	LINX-202	LINX-203
						
BACnet device profile	B-BC	B-BC	-	-	B-BC	B-BC
Power supply	24VDC / 24 VAC ± 10%, typ. 2.5 W					
CPU	Quad-core ARM Cortex-A53 @ 1.1GHz					
RAM/FLASH	1 GB / 8 GB	1 GB / 8 GB	1 GB / 8 GB	1 GB / 8 GB	1 GB / 8 GB	1 GB / 8 GB
LIOB-Connect	-	-	■	■	■	■
TP / FT-10 ports	1	1	1	1	-	-
RS-485 ports	2	1	1	1	2	2
Extension ports	3	1	1	1	1	1
Total number of data points	30000	10000	10000	10000	10000	10000
OPC data points	5000	2000	2000	2000	2000	2000
BACnet objects	2000	2000	-	-	750	750
BACnet client mappings	1000	750	-	-	750	750
BACnet calendar	25	25	-	-	25	25
BACnet scheduler	100	100	-	-	100	100
BACnet notification classes	32	32	-	-	32	32
Trend logs	512 (13 000 000 entries, ≈ 200 MB)		256 (13 000 000 entries, ≈ 200 MB)			
LonMark calendar	1 (25 calendar patterns)	1 (25 calendar patterns)	1 (25 calendar patterns)	1 (25 calendar patterns)	-	-
LonMark scheduler	100	100	100	100	-	-
LonMark alarm servers	1	1	1	1	-	-
L-WEB clients	32	32	32	32	32	32
L-IOB I/O modules	-	-	Up to 8 (LIOB-Connect, LIOB-FT and LIOB-IP852)		Up to 8 (LIOB-Connect, LIOB-FT and LIOB-55x)	
IEC-61131	-	-	-	-	-	-
IEC-61499	-	-	-	-	-	-
CEA-709 Router	-	-	-	■	-	-
CEA-709 RNI	■	■	■	-	-	-
CEA-709 (FT)	■ 1	■ 1	■ 1	■	-	-
CEA-852 (IP)	■ 1	■ 1	■ 1	■	-	-
BACnet Router	-	-	-	-	-	■
BACnet MS / TP	■ 2	■ 2	-	-	■ 2	■
BACnet IP	■ 2	■ 2	-	-	■ 2	■
BBMD	■	■	-	-	-	■
Modbus RTU/ASCII	■	■ 3	■	■	■ 3	■ 3
Modbus IP	■	■	■	■	■	■
M-Bus	■ 4	■ 4	■ 4	■ 4	■ 4	■ 4
KNX TP1	■ 4	■ 4	■ 4	■ 4	■ 4	■ 4
MP-BUS	■ 5	■ 5	■ 5	■ 5	■ 5	■ 5
KNX IP	■ 4	■ 4	■	■	■	■
SMI	■ 5	■ 5	■ 5	■ 5	■ 5	■ 5
EnOcean	■ 5	■ 5	■ 5	■ 5	■ 5	■ 5
OPC XML-DA Client/Server	■	■	■	■	■	■
OPC UA Server	■	■	■	■	■	■
SNMP	■	■	■	■	■	■
128 x 64 graphic display with backlight	■	■	■	■	■	■
USB	■	■	■	■	■	■
Ethernet switch	■	■	■	■	■	■
WLAN	■ 5	■ 5	■ 5	■ 5	■ 5	■ 5
LTE	■ 5	■ 5	■ 5	■ 5	■ 5	■ 5
IoT	■	■	■ 6	■ 6	■ 6	■ 6
SSH, HTTPS, Firewall	■	■	■	■	■	■
LIOB FT + IP	-	-	■	■	■	■
Operating conditions	0 °C to 50 °C, 10–90 % RH, noncondensing, degree of protection: IP40, IP20 (terminals)					
Dimensions (L x W x H, mm)	159 x 100 x 75			107 x 100 x 75		
Certificates	CE, FCC, BTL, UL	CE, FCC, BTL, UL	CE, FCC, UL	CE, FCC, UL	CE, FCC, BTL, UL	CE, FCC, BTL, UL

1. This model can be configured to have either FT or IP active for CEA-709.









2. This model can be configured to have either MS / TP or IP active for BACnet.

3. Modbus RTU/ASCII can only be used if BACnet MS / TP is not active on this model.









4. M-Bus and KNX TP1 can be used alternatively only on this model. To operate these protocols, an expansion module is needed and must be ordered separately.

5. To operate these protocols, an expansion module is needed and must be ordered separately.

6. To operate IoT functionalities, the L-IOT1 software license is needed and must be ordered separately.

Product name	L-VIS Touch Panels							
Model	LVIS7-32G1	LVIS7-32G2	LVIS12-32G1	LVIS12-32G2	LVIS12-32G3	LVIS15-32G1	LVIS15-32G2	LVIS15-32G3
								
Power supply	PoE class 4 24 VDC ±10%, 2.5 W Backlight on: 5 W		PoE class 4 24 V DC ±10 %, 4 W, backlight on: 10 W or 85-240 V AC, 7 W, backlight on: 13 W			PoE class 4 24 V DC ±10 %, 4 W, backlight on: 10 W or 85-240 V AC, 7 W, backlight on: 13 W		
Screen size	7"	7"	12.1"	12.1"	12.1"	15"	15"	15"
Touch display	Capacitive touch							
Display resolution	1024 x 600, 16.7 million colors				1024 x 768, 16.7 million colors			
Panel material	Frameless glass							
Color	Silver	Black	Silver	Black	White	Silver	Black	White
BACnet	■	■	■	■	■	■	■	■
CEA-709	■	■	■	■	■	■	■	■
OPC XML-DA server	■	■	■	■	■	■	■	■
OPC XML-DA clients	■	■	■	■	■	■	■	■
OPC UA server	■	■	■	■	■	■	■	■
OPC data points	10000	10000	10000	10000	10000	10000	10000	10000
Modbus data points	2000	2000	2000	2000	2000	2000	2000	2000
VNC clients	16	16	16	16	16	16	16	16
Alarming	■	■	■	■	■	■	■	■
Scheduling	■	■	■	■	■	■	■	■
Trending	■	■	■	■	■	■	■	■
Web server	■	■	■	■	■	■	■	■
Ethernet ports	2	2	2	2	2	2	2	2
TP / FT-10 ports	1	1	1	1	1	1	1	1
RS-485 ports (Modbus / BACnet)	1	1	1	1	1	1	1	1
Digital Input (DI)	2	2	2	2	2	2	2	2
Speaker and audio output	■	■	■	■	■	■	■	■
Mounting frame	■	■	■	■	■	■	■	■
WLAN	■ 1	■ 1	■ 1	■ 1	■ 1	■ 1	■ 1	■ 1
LTE	■ 1	■ 1	■ 1	■ 1	■ 1	■ 1	■ 1	■ 1
Operating conditions	10°C to 40°C, 10-90% RH, noncondensing							
Dimensions (L x W x H, mm)	223.5 x 162 x 65		333 x 272.5 x 65			394 x 318 x 65		
Dimensions cut-out (L x W x H, mm)	195 x 143 x 61		300 x 250 x 61			355 x 295 x 61		
Certificates	CE, FCC, BTL, UL							

1. To operate these protocols, an expansion module is needed and must be ordered separately.

Product name	L-STAT Room Control Unit					
Model LSTAT-80x-G3-Lx	LSTAT-800-G3-L1 LSTAT-801-G3-L1 LSTAT-802-G3-L1	LSTAT-800-G3-L2 LSTAT-801-G3-L2 LSTAT-802-G3-L2	LSTAT-800-G3-L3 LSTAT-801-G3-L3 LSTAT-802-G3-L3	LSTAT-800-G3-L4 LSTAT-801-G3-L4 LSTAT-802-G3-L4	LSTAT-800-G3-L5 LSTAT-801-G3-L5 LSTAT-802-G3-L5	LSTAT-800-G3-L6 LSTAT-801-G3-L6 LSTAT-802-G3-L6
Black Front, White Enclosure						
Model LSTAT-80x-G3-L20x	LSTAT-800-G3-L201 LSTAT-801-G3-L201 LSTAT-802-G3-L201	LSTAT-800-G3-L202 LSTAT-801-G3-L202 LSTAT-802-G3-L202	LSTAT-800-G3-L203 LSTAT-801-G3-L203 LSTAT-802-G3-L203	LSTAT-800-G3-L204 LSTAT-801-G3-L204 LSTAT-802-G3-L204	LSTAT-800-G3-L205 LSTAT-801-G3-L205 LSTAT-802-G3-L205	LSTAT-800-G3-L206 LSTAT-801-G3-L206 LSTAT-802-G3-L206
White Front, White Enclosure						
Display	LCD display with backlight and choice of RGB color					
RS-485 ports	1	1	1	1	1	1
Button	4	6	8	8	8	8
Power supply	24 VDC ±10%, 1 W					
Buzzer	1	1	1	1	1	1
Internal temperature sensor	1	1	1	1	1	1
Internal relative humidity sensor	1	1	1	1	1	1
Digital Input (DI)	3	3	3	3	3	3
Universal Input (UI)	1	1	1	1	1	1
Motion detection, occupancy, Infrared receiver	1 (LSTAT-801-GX-LX and LSTAT-802-GX-LX)					
CO ₂ sensor	1 (LSTAT-802-GX-LX)					
EnOcean	optional for L-STAT-CUSTOM					
Operating conditions	0°C to 50°C, 10–90% RH, noncondensing					
Dimensions (L x W x H, mm)	94.5 x 110 x 19.5					
Certificates	CE, FCC, UL					

Buttons (capacitive touch)

LSTAT-80x-Gx-Lxx1: 4 x Button with temperature up/down, occupancy, and menu









LSTAT-80x-Gx-Lxx2: 6 x Button with temperature up/down, fan up/down, occupancy, and menu

LSTAT-80x-Gx-Lxx3: 8 x Button with temperature up/down, fan up/down, light on/off, occupancy, and menu

LSTAT-80x-Gx-Lxx4: 8 x Button with temperature up/down, sunblinds up/ down, light on/off, occupancy, and menu

LSTAT-80x-Gx-Lxx5: 8 x Button with temperature up/ down, fan up/ down, sunblinds up/ down, occupancy, and menu













LSTAT-80x-Gx-Lxx6: 8 x Button with temperature up/ down, fan up/ down, sunblinds up/ down, light, and menu



Product name	LPAD-7 Touch Panel			LPAD-7 Touch Panel / Programmable Controller					
Model	LPAD7-30G2	LPAD7-30G3	LPAD7-30G4	LPAD7-31G2	LPAD7-31G3	LPAD7-31G4	LPAD7-41G2	LPAD7-41G3	LPAD7-41G4
									
	G2: black front, white enclosure;			G3: white front, white enclosure;			G4: black front, black enclosure		
CPU	Quad-core ARM Cortex-A53 @ 1.1GHz			Quad-core ARM Cortex-A53 @ 1.1GHz			Quad-core ARM Cortex-A53 @ 1.1GHz		
RAM	1 GByte			1 GByte			1 GByte		
FLASH	8 GByte			8 GByte			8 GByte		
Power supply	PoE class 3, 24 V DC ±10 %, 3 W, backlight on: 6 W								
Display	7" IPS, 1024 x 600, 16.7 million colors, capacitive touch								
OPC XML-DA server	■			■			■		
OPC XML-DA clients	■			■			■		
OPC UA server	■			■			■		
OPC data points	10000			10000			10000		
Modbus data points	-			2000			2000		
VNC clients	16			16			16		
AST	■			■			■		
Web server	■			■			■		
Ethernet ports	2			2			2		
PoE Class 3	■			■			■		
Speaker	■			■			■		
TOF proximity sensor	■			■			■		
Temperature/Humidity	■			■			■		
Lux sensor	■			■			■		
IR receiver	■			■			■		
WLAN	■			■			■		
Microphone	-			-			■		
Max. number of Rooms/Segments	-			2			2		
Bluetooth	■			■			■		
BACnet/IP, BACnet/SC	-			■			■		
BACnet MS/TP	-			■ 1			■ 1		
LonMark IP-852 ²	■ 2			■ 2			■ 2		
LonMark TP/FT-10 ²	■ 2			■ 2			■ 2		
Modbus TCP	-			■			■		
Modbus RTU/ASCII	-			■ 1			■ 1		
EnOcean	■ 3			■ 3			■ 3		
IoT, Node.js, Node-RED	-			■			■		
IEC 61499 / IEC 61131-3 programming	-			■			■		
Degree of protection	IP20								
Operating conditions	+10 °C to 45 °C, 10-90 % RH, noncondensing								
Dimensions	180 x 112.2 x 21 (L x W x H, mm)								
Certificates	CE, FCC			CE, FCC, BTL			CE, FCC, BTL		



1. Needs LPAD7-SOCKET1, LPAD7-SOCKET2, LPAD7-SOCKET3 or LPAD7-SOCKET4 - must be ordered separately.

2. Needs LPAD7-SOCKET2 - must be ordered separately.





3. Needs LPAD7-SOCKET3, or LPAD7-SOCKET4 - must be ordered separately.

Product name	LPAD7-SOCKETx Mounting Sockets					
Model	LPAD7-SOCKET0	LPAD7-SOCKET1	LPAD7-SOCKET2	LPAD7-SOCKET3	LPAD7-SOCKET4	LPAD7-SOCKET5
						
	LPAD7-SOCKET0-B	LPAD7-SOCKET1-B	LPAD7-SOCKET2-B	LPAD7-SOCKET3-B	LPAD7-SOCKET4-B	LPAD7-SOCKET5-B
						
Power supply	24 V DC supply	24 V AC/DC supply	24 V AC/DC supply	24 V AC/DC supply	24 V AC/DC supply	24 V AC/DC supply
RS-485	-	■	■	■	■	-
Universal I/O (IO)	-	7	-	-	-	-
Relays	-	6 Relays 2 A, 24 V	-	-	-	-
LonMark TP/FT-10	-	-	■	-	-	-
EnOcean	-	-	-	868 MHz	902 MHz	-
Interfaces	-	-	3 x digital input (dry contact, not protected against overvoltage)			-
Certificates	CE, FCC, BTL, UL	CE, FCC, BTL, UL	CE, FCC, BTL, UL	CE, FCC, EnOcean certified	CE, FCC, EnOcean certified	CE, FCC, BTL, UL

Product name	L-DALI Controller		
Model	LDALI-3E101-U	LDALI-3E102-U	LDALI-3E104-U
			
Power supply	85-240 V AC, 50/60 Hz, typ. 9 W (4 W + 5 W DALI)	85-240 V AC, 50/60 Hz, typ. 14 W (4 W + 2 x 5 W DALI)	85-240 V AC, 50/60 Hz, typ. 14 W (4 W + 4 x 2.5 W DALI)
CPU	Quad-core ARM Cortex-A53 @ 1.1GHz		
RAM/FLASH	1 GB / 8 GB	1 GB / 8 GB	1 GB / 8 GB
DALI channels	1	2	4
Integrated DALI bus power supply (per channel data)	16 VDC, 230 mA guaranteed supply current, 250 mA max. supply current		16 VDC, 116 mA guaranteed supply current, 125 mA max. supply current
OPC data points	10000	10000	10000
128x64 graphic display with backlight	■	■	■
BACnet Server Objects	-	-	-
CEA-709 Local NVs	1000	2000	4000
OPCXML-DA + UA Server	■	■	■
DALI ballasts per DALI channel	64		
DALI groups per DALI channel	16		
DALI sensor per DALI channel	16		
Scene control	16 scenes per DALI group		
Alarm logs	10		
Scheduler	16 per DALI channel (LonMark)		
Trend logs	512 (13 000 000 entries, ≈ 200 MB)		
Local and Global connections	2000 / 250		
L-WEB clients	32 (simultaneously)		
Ethernet ports	2		
TP / FT-10 ports	1		
BACnet MS / TP ports	-	-	-
WLAN	■ 1	■ 1	■ 1
LTE	■ 1	■ 1	■ 1
L-STUDIO	-	-	-
IoT	■	■	■
Operating conditions	0 °C to 40 °C, 10 – 90 % RH, noncondensing, degree of protection: IP40, IP20 (terminals)		
Dimensions	159 x 100 x 75 (L x W x H, mm)		
Certificates	DALI-2, CE, FCC, UL	DALI-2, CE, FCC, UL	DALI-2, CE, FCC, UL





Product name	L-DALI Power Supply		
Model	LDALI-PWR1-U	LDALI-PWR2-U	LDALI-PWR4-U
			
Power supply	85-240 VAC, 50 / 60 Hz	85-240 VAC, 50 / 60 Hz	85-240 VAC, 50 / 60 Hz
Product descriptions	DALI power supply unit for 1 DALI channels	DALI power supply unit for 2 DALI channels	DALI power supply unit for 4 DALI channels
Operating conditions	0 °C to 40 °C, 10 – 90 % RH, noncondensing, degree of protection: IP40, IP20 (terminals)		
DALI supply current guaranteed / max	1 x 50mA / 62mA	2 x 116mA / 125mA	4 x 116mA / 125mA
Dimensions	51 x 41 x 21 (L x W x H)	107 x 100 x 75 (L x W x H, mm)	
Certificates	DALI-2, CE, FCC	DALI-2, CE, FCC, UL	DALI-2, CE, FCC, UL





1. To operate these protocols, an expansion module is needed and must be ordered separately.

Product name	L-DALI Controller				
Model	LDALI-ME201-U	LDALI-ME202-U	LDALI-ME204-U	LDALI-PLC2	LDALI-PLC4
					
Power supply	85-240 V AC, 50/60 Hz, typ. 9W (4W + 5W DALI)	85-240 V AC, 50/60 Hz, typ. 14W (4W + 2 x 5 W)	85-240 V AC, 50/60 Hz, typ. 14W (4W + 4 x 2.5W DALI)	85-240 V AC, 50/60 Hz, typ. 14W (4W + 2 x 5W DALI)	85-240 V AC, 50/60 Hz, typ. 14W (4W + 4 x 2.5W DALI)
CPU	Quad-core ARM Cortex-A53 @ 1.1GHz				
RAM/FLASH	1 GB / 8 GB	1 GB / 8 GB	1 GB / 8 GB	1 GB / 8 GB	1 GB / 8 GB
DALI channels	1	2	4	2	4
Integrated DALI bus power supply (per channel data)	16 VDC, 230 mA guaranteed supply current, 250 mA max. supply current	16 VDC, 230 mA guaranteed supply current, 250 mA max. supply current	16 VDC, 116 mA guaranteed supply current, 125 mA max. supply current	16 V DC, 230 mA guaranteed supply current, 250 mA max. supply current	16 V DC, 116 mA guaranteed supply current, 125 mA max. supply current
OPC data points	10000	10000	10000	10000	10000
128x64 graphic display with backlight	■	■	■	■	■
BACnet Server Objects	1000	2000	4000	2000	2000
CEA-709 Local NVs	-	-	-	1000	1000
OPCXML-DA + UA Server	■	■	■	■	■
DALI ballasts per DALI channel	64				
DALI groups per DALI channel	16				
DALI sensor per DALI channel	16				
Scene control	16 scenes per DALI group				
Alarm logs	10				
Scheduler	25 per DALI channel (BACnet)			25 per DALI channel (LonMark), 25 per DALI channel (BACnet)	
Trend logs	512 (13 000 000 entries, ≈ 200 MB)				
Local and Global connections	2000 / 250				
L-WEB clients	32 (simultaneously)				
Ethernet ports	2				
TP / FT-10 ports	-		1		1
BACnet MS / TP ports	1	1	1	1	1
WLAN	■ 1	■ 1	■ 1	■ 1	■ 1
LTE	■ 1	■ 1	■ 1	■ 1	■ 1
L-STUDIO	-	-	-	■	■
IoT	■	■	■	■	■
Operating conditions	0 °C to 40 °C, 10 – 90 % RH, noncondensing, degree of protection: IP40, IP20 (terminals)				
Dimensions	159 x 100 x 75 (L x W x H, mm)				
Certificates	DALI-2, CE, FCC, BTL, UL	DALI-2, CE, FCC, BTL, UL	DALI-2, CE, FCC, BTL, UL	DALI-2, CE, FCC, BTL, UL	DALI-2, CE, FCC, BTL, UL

Product name	L-DALI Phase-Cut Dimmer Module
Model	LDALI-PD1
	
Power supply	220-240 V AC, 50/60Hz
Product descriptions	DALI phase-cut dimmer module
Number of devices	64 per DALI channel, with sufficient dimensioned DALI bus power supply
Operating conditions	0°C – 50°C, 10 – 90% RH, non-condensing, degree of protection: IP20
Dimensions (mm)	51 x 41 x 21
Certificates	DALI-2, CE, FCC



1. To operate these protocols, an expansion module is needed and must be ordered separately.

Product name	L-DALI Multisensors				
Model	LDALI-MS2-BT	LDALI-MS2-BT-B	LDALI-MS3-BT	LDALI-MS3-BT-B	LDALI-MS4-BT
					
	White	Black	White	Black	White
Power supply	DALI bus, 6 mA / 10 mA at 16 V DC (Bluetooth disabled/enabled), max. 10mA (inrush current)				
Product descriptions	Multi-sensor with motion detection, lux level measurements and Bluetooth			Multi-sensor with motion detection, lux level measurements, flat lens and Bluetooth	
Dimensions (mm)	Total Ø: 104 flush-mounted Ø: 60 mounting depth: 30		Total Ø: 68 mounting hole Ø: 60 mounting depth: 42		
Installation	Ceiling mount: • Direct installation in false ceilings (spring mount included) • Flush-mounted installation • On-wall (mounting kit LOYMS2-OW must be ordered separately)			Ceiling mount: • Direct installation in false ceilings (spring mount included)	
Number of LDALI-MSx-BT	16 per DALI channel, with sufficient dimensioned DALI bus power supply				
Lux level measurement	0 – 4000 lux, resolution: 0.125 lux				
Mounting height	max. 12 m			max. 5 m	
Passive infrared motion detector	10.8 m @ 3m mounting height (92m ²), 136 zones, opening angle: 122° (up to 5 m mounting height) Highbay-application: 5 m – 12 m mounting height, detection area: 256 m2 (opening angle: 73.6° @ 12 m, 122° @ 5 m)			7.2 m @ 3 m mounting height (44 m2), 156 zones, opening angle: 100° (up to 5 m mounting height)	
Bluetooth	■		■		■
Operating conditions	0 °C to 50 °C, 10 – 90 % RH, noncondensing, degree of protection: IP20				
Certificates	DALI-2, CE, FCC		DALI-2, CE, FCC		DALI-2, CE, FCC

Product name	LOYBT Multisensors				
Model	LOYBT-MS2	LOYBT-MS2-B	LOYBT-MS3	LOYBT-MS3-B	LOYBT-MS4
					
	White	Black	White	Black	White
Power supply	DALI-bus, 6 mA at 16 V DC, max. 15 mA (inrush current) or DC power supply (max. 1A), 6 mA at 12 V DC or 24 V DC				
Product descriptions	Bluetooth SIG Mesh qualified multi-sensor (presence detection, lux sensor, IR receiver, temperature sensor, humidity sensor, 3 digital inputs, Bluetooth Mesh), up to 12 m mounting height			Bluetooth SIG Mesh qualified multi-sensor (presence detection, lux sensor, IR receiver, temperature sensor, humidity sensor, 3 digital inputs, Bluetooth Mesh, flat lens)	
Dimensions (mm)	Total Ø: 104 flush-mounted Ø: 60 mounting depth: 30		Total Ø: 68 mounting hole Ø: 60 mounting depth: 42		
Installation	Ceiling mount: • Direct installation in false ceilings (spring mount included) • Flush-mounted installation • On-wall (surface mounting box included)		Ceiling mount: • Direct installation in false ceilings (spring mount included)		
Mounting height	max. 12 m		max. 12 m		max. 5 m
Passive infrared motion detector	10.8 m @ 3m mounting height (92m ²), 136 zones, opening angle: 122° (up to 5 m mounting height) Highbay-application: 5 m – 12 m mounting height, detection area: 256 m2 (opening angle: 73.6° @ 12 m, 122° @ 5 m)			7.2 m @ 3 m mounting height (44 m2), 156 zones, opening angle: 100° (up to 5 m mounting height)	
Bluetooth	■		■		■
Bluetooth & RF characteristics	Maximum output power: + 8 dBm Frequency range: 2402 - 2480 Mhz				
Operating conditions	0 °C to 50 °C, 10 – 90 % RH, noncondensing, degree of protection: IP20				
Certificates	DALI-2, CE, FCC		DALI-2, CE, FCC		DALI-2, CE, FCC



Product name	Infrared Remote controller
Model	L-RC1
	
Power supply	1 x CR2025 3.0 V button battery
Product descriptions	Infrared remote control for room automation applications
Keys	18
Operating conditions	0°C to 40°C, 10–90% RH, noncondensing
Dimensions	40.5 x 86.4 x 7.20 (L x W x H, mm)
Certificates	CE, FCC









Product name	L-DALI Pushbutton Coupler
Model	LDALI-BM2
	
Power supply	DALI bus 3.5 mA at 16 V DC, max. 6 mA (inrush current)
Product descriptions	Quadruple pushbutton coupler
Number of devices	64 per DALI channel, with sufficient dimensioned DALI bus power supply
Operating conditions	0 °C to 50 °C, 10–90 % RH, noncondensing, degree of protection: IP20
Dimensions	45.8 x 37.8 x 13.5 (L x W x H, mm)
Certificates	DALI-2, CE, FCC







Product name	L-DALI PWM module		
Model	LDALI-PWM4	LDALI-PWM4-TC	LDALI-PWM4-RGBW
			
Power supply	12 - 24V DC +10%		
Product descriptions	PWM module, DALI, 4 x 3 A LED outputs, 24 V DC ext.	PWM module tunable white, DALI, 4 x 3 A LED outputs, 24 V DC ext.	PWM module RGBW, DALI, 4 x 3 A LED outputs, 24 V DC ext.
Number of devices	up to 16 per DALI channel	up to 32 per DALI channel	up to 64 per DALI channel
Operating conditions	0 °C to 50 °C, 10–90 % RH, noncondensing, degree of protection: IP20		
Dimensions (mm)	51 x 41 x 21		
Certificates	DALI-2, CE, FCC	DALI-2, CE, FCC	CE, FCC

Product name	L-DALI Sunblind Module
Model	LOY-DALI-SBM1
	
Power supply	DALI-bus, idle 3.5 mA (@16 V DC) / typ. 6 mA (@ 16 V DC) / max. 11 mA inrush current
Product descriptions	DALI Sunblind Module, DALI, 2 x 6A/250 V AC
Number of devices	64 per DALI channel, with sufficient dimensioned DALI bus power supply
Maximum switching power	1500 VA @ 250 V AC / 180 W @ 30 V DC
Nominal switching capacity	6A @ 250 V AC / 6A @ 30 V DC / inrush currents up to 10A
Relay contact switching voltage	250 V AC / 30 V DC
Interfaces	1 x DALI, protected against overvoltage (mains)
Terminal blocks	Push Terminals
Dimensions (mm)	51 x 41 x 21
Operating conditions	0 °C to 50 °C, 10 – 90 % RH, noncondensing, degree of protection: IP40, IP20 (terminals)
Certificates	DALI-2, CE, FCC

Product name	LOYBT Sunblind Module
Model	LOYBT-SBM1
	
Power supply	Mains voltage (85V-240V AC), 50/60Hz, typ. 4 ma (@230 V AC), eff. power consumption 200 mW
Product descriptions	Bluetooth SIG Mesh qualified Sunblind Module, 2 x 6A/250 V AC
Dimensions (mm)	51 x 41 x 21
Maximum switching power	1500 VA @ 250 V AC
Nominal switching capacity	6A @ 250 V AC / inrush currents up to 10A
Relay contact switching voltage	250 V AC
Interfaces	1 x Bluetooth Interface, 2 x Relay
Interval times	min. switching interval: 200 ms switch-on duration: 70 ms - 655340 ms, infinite resolution: 50 ms
Bluetooth protocol conformance	Declaration ID: Design Number (DN) Q301729 contains qualified designs: 239299 (controller subsystem Bluetooth 5.4), 239354 (host subsystem Bluetooth 5.4) and 226841 (Mesh Protocol 1.1, Mesh Model 1.1)
Operating conditions	0 °C to 50 °C, 10 – 90 % RH, noncondensing, degree of protection: IP40, IP20 (terminals)
Certificates	CE, FCC



Product name	L-DALI Relay module		
Model	LDALI-RM5	LDALI-RM6	LDALI-RM8
			
Power supply	DALI bus, idle 3.5 mA / 3 mA (1-10 V connected / not connected) (@16 V DC), typ. 6 mA (@16 V DC), max. 11 mA (inrush current)		85 – 240 V AC or 24 V DC ±10 %, typ. consumption: < 1 W
Product descriptions	DALI Relay Module 10 A, Analog Interface 1 – 10 V		DALI Relay Module, 8-channel
Number of devices	64 per DALI channel, with sufficient dimensioned DALI bus power supply		max. 8 per DALI channel
Current AC	10 A, 120 V AC; 10 A, 120 V AC; 8 A, 277 V AC; 6 A, 347 V AC		16 A
Current DC	10 A, 30 V DC		16 A, 30 V DC
Relay contact switching voltage	120 - 347 V AC / 30 V DC		120-277 V AC / 30 V DC
Operating conditions	0 °C to 50 °C, 10–90 % RH, noncondensing, degree of protection: IP20		0 °C to 40 °C, 10 – 90 % RH, noncondensing, degree of protection: IP40, IP20 (terminals)
Dimensions	51 x 41 x 21 (L x W x H, mm)		159 x 100 x 75 (L x W x H, mm)
Certificates	DALI-2, CE, FCC		DALI-2, CE, FCC



Product name	L-IP CEA-709 / IP-852 Router					L-IP BACnet IP Router		
Model	LIP-3ECTC	LIP-1ECTC	LIP-13ECTC	LIP-33ECTC	LIP-3333ECTC	LIP-ME201C	LIP-ME202C	LIP-ME204C
								
Power supply	24 V AC / DC \pm 10%							
CPU	Quad-core ARM Cortex-A53 @ 1.1GHz							
RAM/FLASH	1 GB / 8 GB							
OPC XML-DA server	■	■	■	■	■	■	■	■
OPC UA server	■	■	■	■	■	■	■	■
Ethernet ports	2	2	2	2	2	2	2	2
TP / FT-10 ports	1	-	1	2	4	-	-	-
TP / XF-1250 ports	-	1	1	-	-	-	-	-
BACnet MS / TP ports	-	-	-	-	-	1	2	4
Operating conditions	0 °C to 50 °C, 10–90 % RH, noncondensing, degree of protection: IP40, IP20 (terminals)							
Dimensions (L x W x H, mm)	107 x 100 x 60			159 x 100 x 75		107 x 100 x 75		159 x 100 x 75
Certificates	CE, FCC, UL	CE, FCC, UL	CE, FCC, UL	CE, FCC, UL	CE, FCC, UL	CE, FCC, BTL, UL	CE, FCC, BTL, UL	CE, FCC, UL
USB ports	2	2	2	2	2	2	2	2
WLAN	■ ¹	■ ¹	■ ¹	■ ¹	■ ¹	■ ¹	■ ¹	■ ¹
LTE	■ ¹	■ ¹	■ ¹	■ ¹	■ ¹	■ ¹	■ ¹	■ ¹

Product name	NIC for CEA-709 and IP-852 Channels					
Model	NIC852	NIC709-USB100	NIC709-IP3E100C	NIC709-IP1E100C	NIC709-IP4E100C	NIC852-SW
						
Power supply	USB interface	USB interface	24 V AC / DC \pm 10%			-
CPU	-	-	Quad-core ARM Cortex-A53 @ 1.1GHz			-
RAM/FLASH	-	-	1 GB / 8 GB			-
Product description	Floating license via USB hardlock key	USB interface, connects to the USB port of a PC	Remote Network Interface (RNI)			Software license for one PC, connect to IP-852 channel
Ethernet ports	-	-	2	2	2	-
TP / FT-10 ports	-	1	1	-	-	-
TP / XF-1250 ports	-	1	-	1	-	-
TP/ RS-485 ports	-	1	-	-	1	-
USB ports	1	1	2	2	2	-
SNMP	-	-	■	■	■	-
WLAN	-	-	■ ¹	■ ¹	■ ¹	-
LTE	-	-	■ ¹	■ ¹	■ ¹	-
Operating conditions	-	0 °C to 50 °C, 10–90 % RH, noncondensing, degree of protection: IP40, IP20 (terminals)				-
Dimensions (L x W x H, mm)	-	104.4 x 66.5 x 25.5	107 x 100 x 75	107 x 100 x 75	107 x 100 x 75	-
Certificates	CE, FCC	CE, FCC	CE, FCC	CE, FCC	CE, FCC	-
Operating System	Windows 10, Windows 11, Windows Server 2016, Windows Server 2019, Windows Server 2022					

Product name	LPA CEA-709 Protocol Analyzer				
Model	LPA-SET-USB	LPA-IP	LPA-SW	LPA-IP-SW	LPA-USB
					
Product description	Set contains: Network interface NIC709-USB100 and NIC852 for IP-852 / CEA-709 channels, registered to NIC852 / NIC709-USB100	IP-852 Channel Protocol Analyzer bundle contains: Network interface NIC852 for IP-852 channels, registered to NIC852	Protocol Analyzer Software, supports all NIC-709 network interfaces, NIC709 not included	Protocol Analyzer Software for IP-852 channels, supports Remote LPA. NIC852 not included.	Set contains: Network Interface NIC709-USB100 LPA-SW Protocol Analyzer Software for CEA-709 channels, registered to NIC709-USB100
Operating System	Windows 7, Windows 8, Windows 10, Windows Server 2003 (32-bit), Windows Server 2008, Windows Server 2012, Windows Server 2016, Windows Server 2019				

1. To operate these protocols, an expansion module is needed and must be ordered separately.

Product name	M-Bus Interface	
Model	L-MBUS20	L-MBUS80
		
Power supply	24 V AC / DC ±10%	
Baud rate	300 to 9600 baud	300 to 9600 baud
TTL / RS-232	1	1
M-Bus	1	1
M-Bus devices	Up to 20	Up to 80
Operating conditions	0 °C to 50 °C, 10–90 % RH, noncondensing, degree of protection: IP40, IP20 (terminals)	
Dimensions (L x W x H, mm)	107 x 100 x 60	
Certificates	CE, FCC	CE, FCC



Product name	EnOcean Interface		
Model	LENO-800	LENO-801	LENO-802
			
Power supply	Via the USB 2.0 BUS Connection		
Frequency	868.3 MHz	902.875 MHz	928.35 MHz
Installation	Standard USB 2.0 cable, max 5 M		
Data rate	125 kbit/s		
Operating conditions	0 °C to 50 °C, 10–90 % RH, noncondensing, degree of protection: IP40, IP20 (terminals)		
Versions	Europe	USA / Canada	Japan
Dimensions (L x W x H, mm)	27 x 89 x 60		
Certificates	CE, FCC	CE, FCC	CE, FCC

Product name	Wireless LAN Interface
Model	LWLAN-800
	
Power supply	via the USB 2.0 bus connection
Installation	standard USB 2.0 cable, max 5 M
USA (FCC)	2.412~2.462 GHz / 11 channels
Europe (ETSI)	2.412~2.472 GHz / 13 channels
Japan	2.412~2.472 GHz / 13 channels
Frequency	2.4 GHz band
Standard	IEEE 802.11 b/g/n
RF output power	max. 18 dBm (63 mW) ±2 dBm
Operating conditions	0 °C to 50 °C, 10–90 % RH, noncondensing, degree of protection: IP40, IP20 (terminals)
Dimensions (L x W x H, mm)	27 x 89 x 60
Certificates	CE, FCC, IC

Product name	LTE Interface
Model	LTE-800
	
Power supply	24 V DC, typ 4.5 W
Installation	standard USB 2.0 cable, max 5 M
Standard	LTE, UMTS/HSPA+ and GSM/GPRS/EDGE
Operating conditions	0 °C to 50 °C, 10–90 % RH, noncondensing, degree of protection: IP40, IP20 (terminals)
Dimensions (L x W x H, mm)	55 x 100 x 60
Certificates	CE, FCC





Product name	KNX TP1 Interface
Model	LKNX-300
	
Power supply	via KNX TP1 bus
Baud rate	9600 baud
Installation	3-wire cable, max 1 M
EXT ports	1
KNX TP1 ports	1
Number of KNX TP1 data points	1000
Operating conditions	0 °C to 50 °C, 10–90 % RH, noncondensing, degree of protection: IP40, IP20 (terminals)
Dimensions (L x W x H, mm)	55 x 100 x 60
Certificates	CE, FCC

Product name	MP-Bus Interface
Model	LMPBUS-804
	
Power supply	24 V DC
Interfaces	1 x Mini USB 2.0 Type B
MP-Bus	4
Operating conditions	0 °C to 50 °C, 10–90 % RH, noncondensing, degree of protection: IP40, IP20 (terminals)
Dimensions (L x W x H, mm)	55 x 100 x 60
Certificates	CE, FCC



Product name	Standard Motor Interface, SMI	
Model	LSMI-800	LSMI-804
		
Product description	Standard Motor Interface for 16 motors via EXT port	Standard Motor Interface for 64 motors, 4 SMI channels via USB
Power supply	230 VAC, 50 Hz, max 2 W	85-240 VAC, 50/60 Hz, max 2W
Installation	3-wire cable, max 1 M	standard USB 2.0 cable, max 1 M
Operating conditions	0 °C to 50 °C, 10–90 % RH, noncondensing, degree of protection: IP40, IP20 (terminals)	
Dimensions (L x W x H, mm)	55 x 100 x 60	107 x 100 x 60
Certificates	CE, FCC	



Product name	RS-232 Interface	
Model	LRS232-802	
		
Power supply	Via the USB 2.0 bus connection	
Installation	DIN rail mounting following DIN 43880, top hat rail EN 50022 Connected with a standard USB 2.0 cable, max. 0.5 m	
Interfaces	1 x Mini USB 2.0 Type B 2 x RS-232 ports: Modbus ASCII (Master or Slave) or custom serial protocols (requires L-IOT1 license)	
Operating conditions	0 °C to 50 °C, 10–90 % RH, noncondensing, degree of protection: IP40, IP20 (terminals)	
Dimensions (L x W x H, mm)	27 x 89 x 60	
Certificates	CE, FCC	



Product name	Dual Single-Pair-Ethernet Converter	
Model	LOY-SPE2	
		
Power supply	24 V DC / V AC SELV ±10 % via LPOW-2415B, or with an external power supply	
Installation	DIN rail mounting following DIN 43880, top hat rail EN 50022	
Power consumption	1.2 W	
Operating conditions	0 °C to 50 °C, 10–90 % RH, noncondensing, degree of protection: IP40, IP20 (terminals)	
Dimensions (L x W x H, mm)	27 x 89 x 60	
Certificates	CE, FCC	

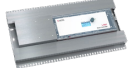

Product name	Network Terminator				
Model	LT-03	LT-13	LT-33	LT-04	LT-B4
					
Power supply	-	-	-	-	24 VDC or 24 VAC ±10%
RJ-45 ports	1	-	-	1	-
TP / FT-10 ports	1	1	2	-	-
TP / XF-1250 ports	-	1	-	-	-
RS-485	-	-	-	1	1
Operating conditions	0°C to 50°C, 10–90% RH, noncondensing				
Dimensions (L x W x H, mm)	27 x 89 x 60				
Certificates	CE, FCC	CE, FCC	CE, FCC	CE, FCC	CE, FCC



RS-485 standard: ANSI/TIA/EIA-485

Product name	L-POW Power Supply		
Model	LPOW-2415A	LPOW-2415B	LPOW-2460B
			
Input voltage	85–240 VAC, 50–60 Hz		
Supply voltage	24 V DC 15 W	24 V DC 15 W	24 V DC 60 W
Connection	via LIOB-Connect	Connector	Connector
Dimensions (L x W x H, mm)	55 x 100 x 60		71 x 91 x 55
Certificates	CE, FCC, UL		CE, FCC



Product name	System Distribution Box		
Model	LBOX-600	LBOX-ROC1	LBOX-ROC2
			
Material	Galvanized steel		
Application	Room automation components	System distribution box for LROC-40x Room Controller	
Dimensions (L x W x H, mm)	600 x 250 x 82	519 x 280 x 71	
Input voltage	-	100 – 240 VAC, 50 – 60 Hz	
Supply voltage	-	24 VDC 60 W	

Product name	L-ACT Actuators		
Model	L-ACT101-MP	L-ACT101-MP	L-ACT-FRAME1
			
Dimensions (L x W x H, mm)	116 x 66 x 63	116 x 66 x 63	214 x 68 x 118
Shaft diameter (inches)	5/8"	3/4"	-
Certificates	CE, FCC, UL		

Product name	Ethernet Switch	
Model	LOYDVS-110W02-3SFP Managed 10-Port Ethernet Switch	LOYDVS-008I00 Unmanaged 8-Port Fast Ethernet
		
Dimensions (L x W x H, mm)	75 x 108.7 x 145.3 (L x W x H)	
Installation	Industrial DIN-Rail and wall mounting	
Certificates	CE, FCC, UL	

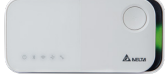
Product name	DVP Modbus I/O Extension	
Model	LOYDVP16SM11N I/O Extension Module	LOYRTU-485 Remote I/O Communication Module
		
Dimensions (L x W x H, mm)	25.2 x 60 x 96 (L x W x H)	25.2 x 60 x 96 (L x W x H)
Installation	Industrial DIN-Rail and wall mounting	Industrial DIN-Rail and wall mounting
Certificates	CE, FCC, UL	

Product name	Indoor air quality sensor	
Model	LOYUNO-L	
		
Dimensions (mm)	141.91 x 42 x 67.91 (L x W x H)	
Installation	Drywall mount, Electrical box mount, wall mount cradle	
Power supply	source 1: 12-24 VDC, 24 VAC source 2: power adapter 12V/1A 6W max. (12VDC)	
Bluetooth & RF-characteristics	Maximum output power: 0 dBm Frequency range: 2402-2480 MHz	
Operating conditions	0 °C to 50 °C, 10 – 90 % RH	
Interfaces	Modbus RTU / BACnet MS/TP (Select via DIP switch)	
Certificates	CE, FCC, UL	
For use with	Bluetooth Mesh enabled LOYTEC devices (e.g. LPAD-7)	

Product name	LOYBT Bluetooth Mesh Sensor	
Model	LOYBT-TEMP1	LOYBT-TEMP2
		
Dimensions (mm)	30 x 13 (Ø x H)	
Power supply	Battery powered (CR2032), expected battery life time: 1 year	
Product descriptions	Bluetooth Mesh temperature sensor	
Interfaces	1x Bluetooth Mesh (low power node) 1x Button (digital input) 1x Led (optical feedback)	
Installation	Wall mounted (screw or adhesive tape)	
Sensor Data Update	Periodically: 5 minutes interval Change of Temperature Value: >0.5° since last publication	Periodically: 5 minutes interval Change of Temperature Value: >0.5° since last publication Change from Unoccupied to Occupied
Bluetooth & RF-characteristics	Maximum output power: +4 dBm Frequency range: 2402-2480 MHz	
Occupancy detection	-	Vibration
Bluetooth protocol conformance	Bluetooth 5.1 Declaration ID: D060851 contains qualified designs: 150092 (controller subsystem), 176697 (host subsystem) and 178269 (mesh profile subsystem)	
Operating conditions	0 °C to 50 °C, 10 – 90 % RH, noncondensing, degree of protection: IP20	
For use with	Bluetooth Mesh enabled LOYTEC devices (e.g. LPAD-7)	

Intelligent Building Automation Solutions that create Value.

fully integrated - seamlessly connected - securely networked



Modern building automation is characterized by the integration of multiple systems and the use of the resulting synergies.

The ability to maximize energy efficiency while maximizing comfort and flexibility is paramount for today's buildings. Transparency in energy consumption and costs is required to immediately detect any weaknesses and to actively develop improvement processes.

LOYTEC sets the target to transform these requirements in best possible product solutions. The result is an innovative product portfolio with consistent and coordinated products. Thereby, LOYTEC relies on open communication protocols emphasizing communication via Ethernet/IP and WLAN/IP to ensure seamless connection to the Intranet/Internet. LOYTEC focuses on the international standards ISO 16484-5 (BACnet), ISO/IEC 14908-1 (LON), ISO/IEC 14543 (KNX), IEC 62386

2014 (DALI), and OPC. In addition, EnOcean (radio), SMI (sunblinds), M-Bus (meter), MP-Bus (Belimo), LTE and Modbus are supported.

LOYTEC accepted no compromises in the development of the building management system LWEB-900, as it constitutes the basis of properly managing technical plants in a building or in distributed real estates.

Highest energy efficiency and a transparent management of technical building installations require a seamlessly integrated building automation system. Especially heating, ventilation, air conditioning, lighting, and sun protection are essential. The LOYTEC L-INX Automation Servers and L-ROC Room Controllers are able to manage and integrate the corresponding subsystem in highly efficient ways.



LOYTEC electronics GmbH
Blumengasse 35
1170 Vienna
Austria

www.loytec.com
info@loytec.com

Delta Electronics (Americas), Inc.
LOYTEC
Building Automation Business
Group
N27 W23957 Paul Road, Suite 103
Pewaukee, WI 53072, USA
www.loytec-america.com
info@loytec-america.com

Delta Electronics, Inc.
256 Yangguang Street
Neihu, Taipei 11491
Taiwan, R.O.C.

www.deltaww.com
bas.sales@deltaww.com

AST, LC3020, L-Chip, L-Core, L-DALI, L-ENO, L-GATE, L-INX, L-IOB, LIOB-AIR, LIOB-Connect, LIOB-FT, L-IOT, L-IP, L-KNX, L-MBUS, L-MPBUS, L-OPC, LPA, L-POW, L-Proxy, L-ROC, L-SMI, L-PAD, L-STAT, L-STUDIO, L-Switch[®], L-TE, L-Term, L-VIS, L-WEB, L-WLAN, ORION Stack, Smart Auto-Connect, buildings under control are trademarks of LOYTEC electronics GmbH.

Echelon, LON, LONWORKS, LNS, LonMaker, and Neuron are trademarks of Echelon Corporation registered in the United States and other countries. LonMark and the LonMark Logo are registered trademarks owned by LonMark International. BACnet is a registered trade mark of the American Society of Heating, Refrigerating and Air Conditioning Engineers, Inc. (ASHRAE). KNX Association cvba is the owner of the worldwide standard for Home and Building Control: KNX and also the owner of the KNX trademark logo worldwide. DiiA, DALI and DALI-2 logos are registered trademarks of the Digital Illumination Interface Alliance. EnOcean[®] and the EnOcean logo are registered trademarks of EnOcean GmbH. Other trademarks and trade names used in this document refer either to the entities claiming the markets and names, or to their products. LOYTEC disclaims proprietary interest in the markets and names of others. Photos: Adobe Stock Library, Marco Liotta, gyn9037/Shutterstock.com, chombosan/Shutterstock.com

Statements in this report that relate to future results and events are based on the company's current expectations. Actual results in future periods may differ materially from those currently expected or desired because of a number of risks and uncertainties.

No part of this publication may be reproduced, stored in a retrieval system, or transmitted, in any form or by any means, electronic, mechanical, photocopying, recording, or otherwise, without the prior written permission of LOYTEC. Product specifications, availability, and design are subject to change without prior notice.

Photos: Marco Liotta, Adobe Stock

©2025

04013816